

Centrifugal pumps

► Medium flow rates



PERFORMANCE RANGE

- Flow rate up to **600 l/min** (36 m³/h)
- Head up to **39 m**

APPLICATION LIMITS

- Manometric suction lift up to **7 m**
- Liquid temperature between **-10 °C** and **+90 °C**
- Ambient temperature up to **+40 °C**
- Max. working pressure:
 - **6 bar** for HF 5-50-51
 - **10 bar** for HF 5M-70
- Continuous service **S1**

CONSTRUCTION AND SAFETY STANDARDS

EN 60034-1
IEC 60034-1
CEI 2-3



REGULATION (EU) N. 547/2012

CERTIFICATIONS

COMPANY WITH MANAGEMENT SYSTEM
CERTIFIED BY DNV
ISO 9001: QUALITY
ISO 14001: ENVIRONMENT AND SAFETY



AN30



NPOMTECT-168

INSTALLATION AND USE

Suitable for use in civil and agricultural applications. The high efficiency and continuous duty capabilities makes these pumps ideal for use in activities such as flood and spray irrigation, drawing water from lakes, rivers and wells, or for any number of different industrial applications where the characteristics of high flow rates and mid to low head are required. The pump should be installed in an enclosed environment, or at least sheltered from inclement weather.

OPTIONALS AVAILABLE ON REQUEST

- Special mechanical seal
- Other voltages or 60 Hz frequency
- IP X5 class protection for HF 70, HF 5BM, HF 5AM

GUARANTEE

2 years subject to terms and conditions

CHARACTERISTIC CURVES AND PERFORMANCE DATA

50 Hz n= 2900 1/min HS= 0 m

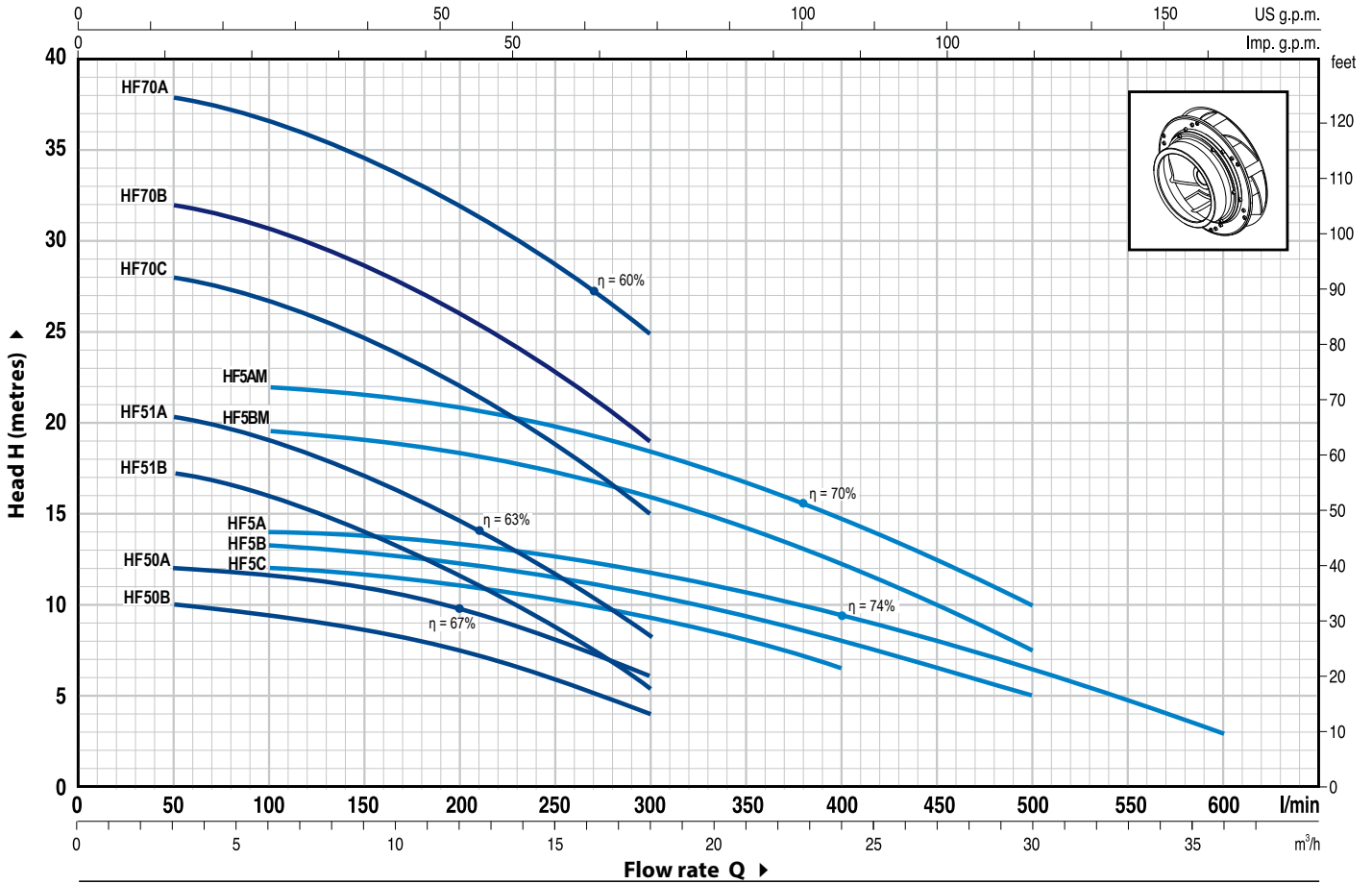

MODEL		POWER		Q	H metres												
Single-phase	Three-phase	kW	HP		m ³ /h	0	3	6	9	12	15	18	21	24	30	36	
				l/min	0	50	100	150	200	250	300	350	400	500	600		
HFm 50B	HF 50B	0.37	0.50		10	10	9.5	8.5	7.5	6	4						
HFm 50A	HF 50A	0.55	0.75		12	12	11.5	11	9.6	8	6						
HFm 51B	HF 51B	0.60	0.85		18.2	17.2	16	14	11.5	9	5.4						
HFm 51A	HF 51A	0.75	1		21.2	20.2	19	17	14.5	11.6	8.4						
HFm 70C	HF 70C	1.1	1.5		29	28	26.5	24.5	22	18.5	15						
HFm 70B	HF 70B	1.5	2		33	32	30.5	28.5	26	22.5	19						
-	HF 70A	2.2	3		39	38	36.5	34.5	32	28.5	25						
HFm 5C	HF 5C	0.60	0.85		12.5	-	12	11.7	11	10.2	9.2	8	6.5				
HFm 5B	HF 5B	0.75	1		13.7	-	13.2	13	12.5	11.6	10.5	9.2	8	5			
HFm 5A	HF 5A	1.1	1.5		14.5	-	13.8	13.5	13.2	12.6	11.8	10.5	9.2	6.5	3		
HFm 5BM	HF 5BM	1.1	1.5		20.2	-	19.2	19	18	17	16	14	12	7.5			
HFm 5AM	HF 5AM	1.5	2		22.5	-	22	21.5	21	20	18.5	16.6	14.5	10			

Q = Flow rate H = Total manometric head HS = Suction height

Tolerance of characteristic curves in compliance with EN ISO 9906 Grade 3.

POS.	COMPONENT	CONSTRUCTION CHARACTERISTICS					
1	PUMP BODY	Cast iron, complete with threaded ports in compliance with ISO 228/1					
2	BODY BACKPLATE	Stainless steel AISI 304 (cast iron for HF 70-5M)					
3	IMPELLER	Brass					
4	MOTOR SHAFT	Stainless steel EN 10088-3 - 1.4104					
5	MECHANICAL SEAL	<i>Pump</i>	<i>Seal</i>	<i>Shaft</i>	<i>Materials</i>		
		<i>Model</i>	<i>Model</i>	<i>Diameter</i>	<i>Stationary ring</i>	<i>Rotational ring</i>	<i>Elastomer</i>
		HF 50	AR-12	Ø 12 mm	Ceramic	Graphite	NBR
		HF 5-51	AR-14	Ø 14 mm	Ceramic	Graphite	NBR
	HF 5M-70	FN-18	Ø 18 mm	Graphite	Ceramic	NBR	
6	BEARINGS	<i>Pump</i>	<i>Model</i>				
		HF 50	6201 ZZ / 6201 ZZ				
		HF 5-51	6203 ZZ / 6203 ZZ				
		HF 5M-70	6204 ZZ / 6204 ZZ				
7	CAPACITOR	<i>Pump</i>	<i>Capacitance</i>				
		<i>Single-phase</i>	<i>(230 V or 240 V)</i>	<i>(110 V)</i>			
		HFm 50B	10 µF 450 VL	25 µF 250 VL			
		HFm 50A	14 µF 450 VL	25 µF 250 VL			
		HFm 51B	20 µF 450 VL	60 µF 300 VL			
		HFm 51A	20 µF 450 VL	60 µF 300 VL			
		HFm 70C	25 µF 450 VL	60 µF 250 VL			
		HFm 70B	45 µF 450 VL	80 µF 250 VL			
		HFm 5C	16 µF 450 VL	60 µF 300 VL			
		HFm 5B	20 µF 450 VL	60 µF 300 VL			
		HFm 5A	25 µF 450 VL	60 µF 300 VL			
		HFm 5BM	25 µF 450 VL	60 µF 250 VL			
		HFm 5AM	45 µF 450 VL	80 µF 250 VL			
8	ELECTRIC MOTOR	HFm: single-phase 230 V - 50 Hz with thermal overload protector built-in to the winding. HF: three-phase 230/400 V - 50 Hz. ⇒ Pumps fitted with the three-phase motor option offer IE2 (IEC 60034-30) class high performance - Insulation: F class. - Protection: IP X4.					

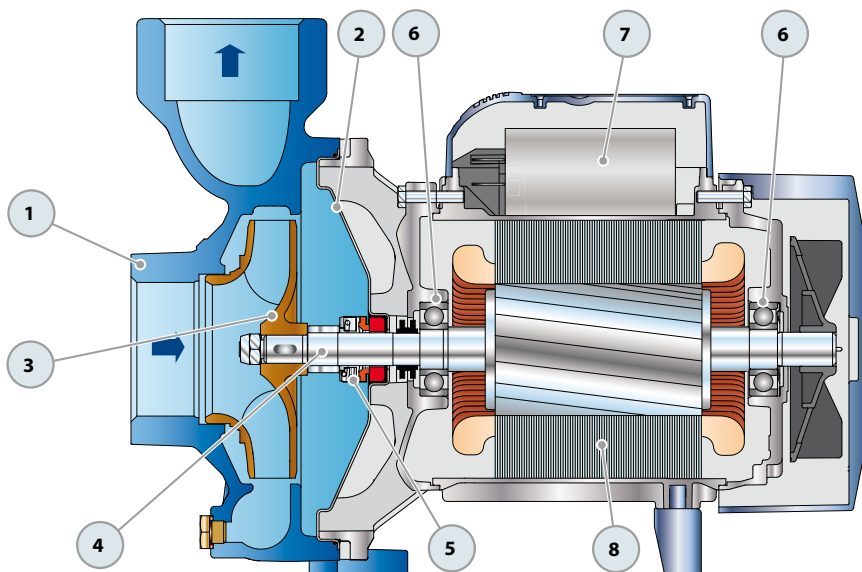

DIMENSIONS AND WEIGHT

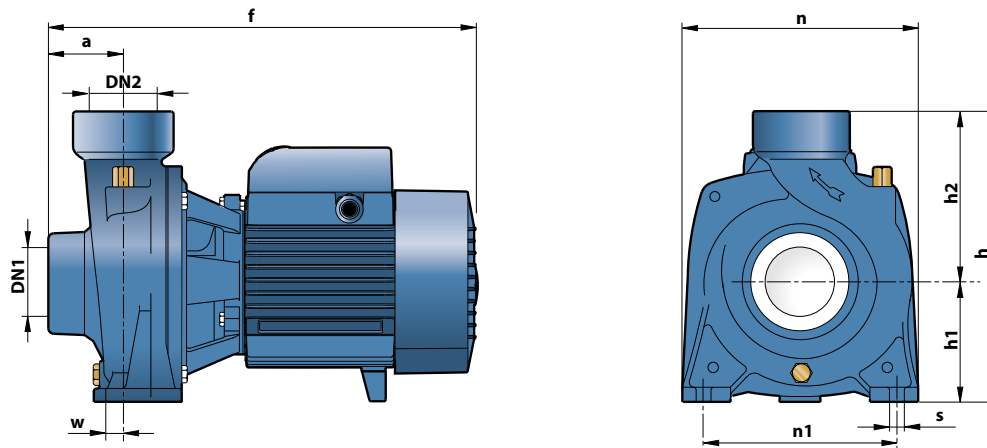

MODEL		PORTS		DIMENSIONS mm								kg			
Single-phase	Three-phase	DN1	DN2	a	f	h	h1	h2	n	n1	w	s	1~	3~	
HFm 50B	HF 50B	1½"	1½"	42	265	200	82	118	166	135	-3	10	8.1	7.6	
HFm 50A	HF 50A			45	300	225	92	133	190	160	4		8.7	8.3	
HFm 51B	HF 51B			45	300	225	92	133	190	160	4		12.9	11.9	
HFm 51A	HF 51A			48.5	373	269	114	155	216	171	12	12	19.0	18.6	
HFm 70C	HF 70C														
HFm 70B	HF 70B														
-	HF 70A	-	-	-	-	-	-	-	-	-	-	-	21.8	20.5	
HFm 5C	HF 5C	2"	2"	43	316	238	97	141	192	160	-68	10	14.5	13.3	
HFm 5B	HF 5B												14.5	13.3	
HFm 5A	HF 5A												15.3	14.9	
HFm 5BM	HF 5BM			51	386	260	110	150	206	1	11	19.5	18.9		
HFm 5AM	HF 5AM													22.0	20.9

ABSORPTION

MODEL	VOLTAGE (single-phase)		
	230 V	240 V	110 V
Single-phase			
HFm 50B	2.8 A	2.6 A	5.6 A
HFm 50A	3.8 A	3.5 A	7.6 A
HFm 51B	4.7 A	4.6 A	9.2 A
HFm 51A	5.6 A	5.3 A	11.2 A
HFm 70C	8.0 A	7.6 A	16.0 A
HFm 70B	10.0 A	9.0 A	20.0 A
HFm 5C	4.2 A	3.8 A	8.4 A
HFm 5B	4.9 A	4.5 A	10.0 A
HFm 5A	6.2 A	5.7 A	12.5 A
HFm 5BM	7.7 A	7.1 A	14.8 A
HFm 5AM	9.8 A	9.0 A	19.6 A

MODEL	VOLTAGE (three-phase)					
	230 V	400 V	690 V	240 V	415 V	720 V
Three-phase						
HF 50B	2.1 A	1.2 A	0.7 A	2.1 A	1.2 A	0.7 A
HF 50A	3.0 A	1.7 A	1.0 A	3.0 A	1.75 A	1.0 A
HF 51B	3.6 A	2.1 A	1.2 A	3.8 A	2.2 A	1.3 A
HF 51A	4.4 A	2.5 A	1.5 A	4.0 A	2.3 A	1.3 A
HF 70C	5.7 A	3.3 A	1.9 A	5.5 A	3.2 A	1.8 A
HF 70B	7.4 A	4.3 A	2.5 A	7.1 A	4.1 A	2.4 A
HF 70A	9.5 A	5.5 A	3.2 A	9.1 A	5.3 A	3.1 A
HF 5C	3.5 A	2.0 A	1.15 A	3.3 A	1.9 A	1.1 A
HF 5B	3.6 A	2.1 A	1.2 A	3.5 A	2.0 A	1.2 A
HF 5A	5.0 A	2.9 A	1.7 A	4.8 A	2.8 A	1.6 A
HF 5BM	5.7 A	3.3 A	1.9 A	5.5 A	3.2 A	1.8 A
HF 5AM	7.1 A	4.1 A	2.4 A	6.5 A	3.7 A	2.1 A

PALLETIZATION

MODEL		GROUPAGE				CONTAINER			
Single-phase	Three-phase	n° pumps	H (mm)	kg		n° pumps	H (mm)	kg	
				1~	3~			1~	3~
HFm 50B	HF 50B	75	1290	630	590	135	2210	1110	1050
HFm 50A	HF 50A	75	1290	670	640	135	2210	1190	1140
HFm 51B	HF 51B	70	1430	920	850	112	2200	1460	1350
HFm 51A	HF 51A	70	1430	930	860	112	2200	1480	1360
HFm 70C	HF 70C	36	1470	700	690	54	2130	1050	1020
HFm 70B	HF 70B	36	1470	800	760	54	2130	1200	1130
-	HF 70A	36	1470	-	810	54	2130	-	1200
HFm 5C	HF 5C	60	1540	890	820	84	2100	1240	1140
HFm 5B	HF 5B	60	1540	890	820	84	2100	1240	1140
HFm 5A	HF 5A	60	1540	940	910	84	2100	1300	1270
HFm 5BM	HF 5BM	50	1540	990	960	70	2100	1380	1340
HFm 5AM	HF 5AM	50	1540	1120	1060	70	2100	1560	1480

