



### PERFORMANCE RANGE

- Flow rate up to **120 l/min** (7.2 m<sup>3</sup>/h)
- Head up to **105 m**

### APPLICATION LIMITS

- Maximum liquid temperature **+40 °C**
- Maximum sand content **50 g/m<sup>3</sup>**
- **20 m** maximum immersion depth
- Continuous service **S1**

### CONSTRUCTION AND SAFETY STANDARDS

⇒ Complete with **20 m** long power cable

EN 60335-1  
IEC 60335-1  
CEI 61-150

EN 60034-1  
IEC 60034-1  
CEI 2-3



### CERTIFICATIONS

COMPANY WITH MANAGEMENT SYSTEM  
CERTIFIED BY DNV  
ISO 9001: QUALITY  
ISO 14001: ENVIRONMENT AND SAFETY



AN30

### INSTALLATION AND USE

As a result of their high efficiency and reliability they are suitable for use with clean water in domestic, civil and agricultural applications such as the distribution of water in combination with pressure sets, for the irrigation of gardens and allotments and for pressure boosting, etc.

### OPTIONALS AVAILABLE ON REQUEST

- Pumps fitted with power cables of other lengths
- Other voltages or 60 Hz frequency

### GUARANTEE

2 years subject to terms and conditions

**CHARACTERISTIC CURVES AND PERFORMANCE DATA**

**50 Hz n = 2900 1/min**

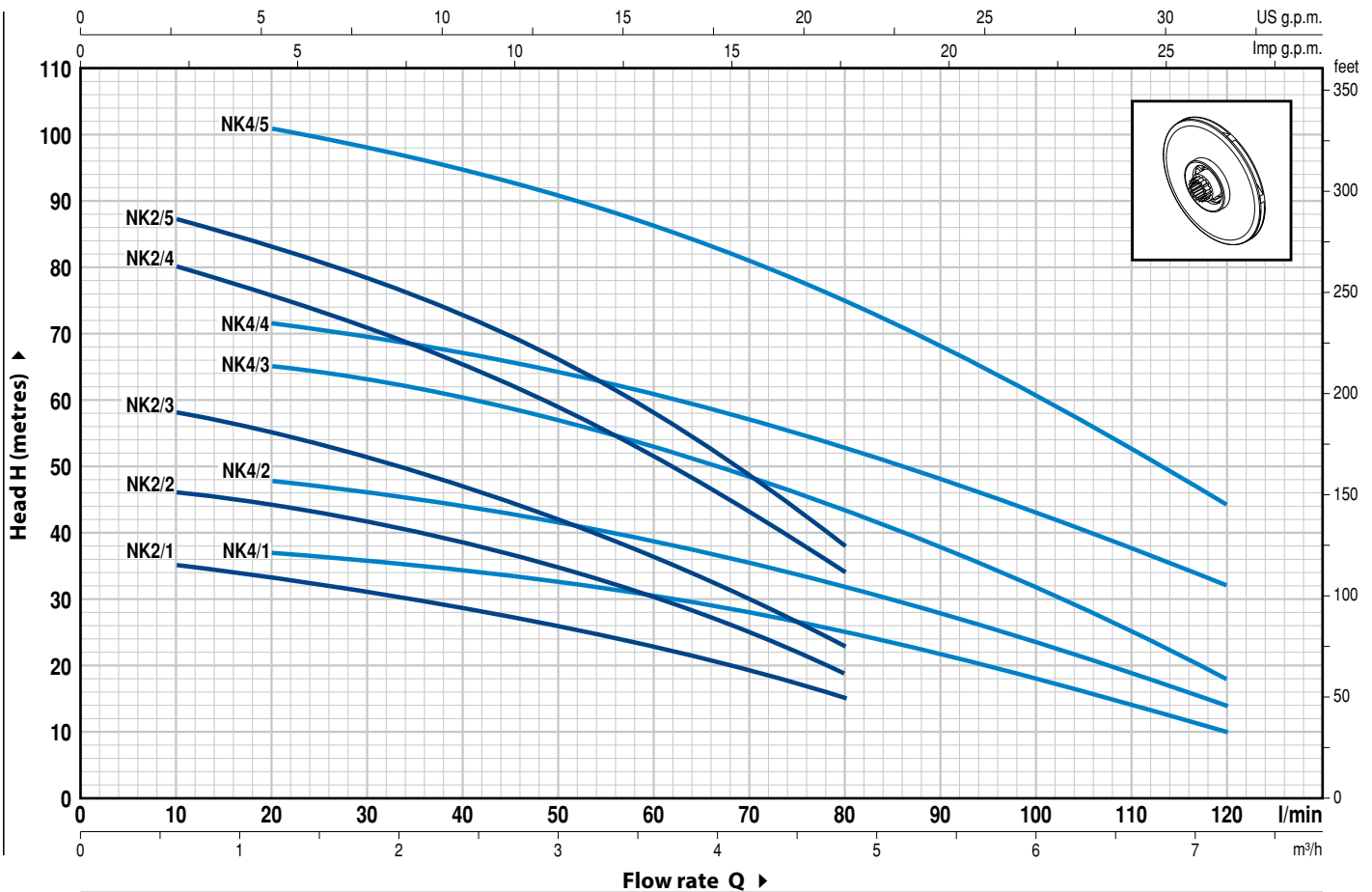

**VERSION WITHOUT FLOAT SWITCH**

MODEL		POWER		Q	Flow rate (l/min)												
Single-phase	Three-phase	kW	HP		0	0.6	1.2	1.8	2.4	3.0	3.6	4.2	4.8	5.4	6.0	6.6	7.2
NKm 2/1	-	0.45	0.6	H metres	36	35	33	31	28.5	26	23	19	15				
NKm 2/2	-	0.55	0.75		48	46	44	41.5	39	35	30	25	19				
NKm 2/3	NK 2/3	0.75	1		60	58	55	51	47	42	36	30	23				
NKm 2/4	NK 2/4	1.1	1.5		84	80	75	70	65	59	51	42.5	34				
NKm 2/5	NK 2/5	1.5	2		90	87	83	78	73	66	58	48	38				
NKm 4/1	-	0.55	0.75		40	-	37	36	34.5	32.5	30	28	25	21.5	18.5	14.5	10
NKm 4/2	NK 4/2	0.75	1		50	-	48	46	44	41	38	35	32	28	24	19	14
NKm 4/3	NK 4/3	1.1	1.5		67	-	65	62.5	60	56.5	52	48	44	38	32	25	18
NKm 4/4	NK 4/4	1.5	2		75	-	72	69	66	64	60	57	53	48	43	38	32
NKm 4/5	NK 4/5	2.2	3		105	-	101	98	94	90	86	80	75	67	60	52	44

**"GE" VERSION WITH FLOAT SWITCH**

MODEL		POWER		Q	Flow rate (l/min)												
Single-phase		kW	HP		0	0.6	1.2	1.8	2.4	3.0	3.6	4.2	4.8	5.4	6.0	6.6	7.2
NKm 2/1 - GE		0.45	0.6	H metres	36	35	33	31	28.5	26	23	19	15				
NKm 2/2 - GE		0.55	0.75		48	46	44	41.5	39	35	30	25	19				
NKm 2/3 - GE		0.75	1		60	58	55	51	47	42	36	30	23				
NKm 2/4 - GE		1.1	1.5		84	80	75	70	65	59	51	42.5	34				
NKm 2/5 - GE		1.5	2		90	87	83	78	73	66	58	48	38				
NKm 4/1 - GE		0.55	0.75		40	-	37	36	34.5	32.5	30	28	25	21.5	18.5	14.5	10
NKm 4/2 - GE		0.75	1		50	-	48	46	44	41	38	35	32	28	24	19	14
NKm 4/3 - GE		1.1	1.5		67	-	65	62.5	60	56.5	52	48	44	38	32	25	18
NKm 4/4 - GE		1.5	2		75	-	72	69	66	64	60	57	53	48	43	38	32
NKm 4/5 - GE		2.2	3		105	-	101	98	94	90	86	80	75	67	60	52	44

Q = Flow rate H = Total manometric head

Tolerance of characteristic curves in compliance with EN ISO 9906 Grade 3.

POS.	COMPONENT	CONSTRUCTION CHARACTERISTICS				
1	EXTERNAL SLEEVE	Stainless steel AISI 304, complete with threaded delivery port in compliance with ISO 228/1				
2	SUCTION FILTER	Stainless steel AISI 304				
3	MOTOR SLEEVE	Stainless steel AISI 304				
4	IMPELLERS AND DIFFUSERS	Noryl GFN2V				
5	DIAPHRAGMS	Stainless steel AISI 304, complete with anti-wear ring				
6	MOTOR SHAFT	Stainless steel EN 10088-3 - 1.4104				
7	<b>TWO MECHANICAL SEALS SEPARATED BY AN OIL CHAMBER</b>					
	<i>Seal</i>	<i>Shaft</i>	<i>Position</i>	<i>Stationary ring</i>	<i>Rotational ring</i>	<i>Materials</i>
	<i>Model</i>	<i>Diameter</i>				<i>Elastomer</i>
	ST1-16	Ø 16 mm	Motor side	Silicon carbide	Graphite	NBR
	ST1-15 SIC	Ø 15 mm	Pump side	Silicon carbide	Graphite	NBR
8	BEARINGS	6303 2RS - C3 / 6203 ZZ - C3				
9	<b>CAPACITOR</b>					
	<i>Pump</i>	<i>Capacitance</i>				
	<i>Single-phase</i>	<i>(230 V or 240 V)</i>	<i>(110 V)</i>			
	NKm 2/1	16 µF 500 VL	30 µF 250 VL			
	NKm 2/2	16 µF 500 VL	30 µF 250 VL			
	NKm 4/1					
	NKm 2/3	20 µF 500 VL	-			
	NKm 4/2					
	NKm 2/4	25 µF 500 VL	-			
	NKm 4/3					
10	<b>ELECTRIC MOTOR</b>					
	NKm: single-phase 230 V - 50 Hz with thermal overload protector built-in to the winding.					
	NK: three-phase 400 V - 50 Hz.					
	- Insulation: F class.					
	- Protection: IP X8.					
11	<b>POWER CABLE</b>					
	⇒ 20 metre long DRINCABLE® for permanent immersion in drinking water					
12	<b>FLOAT SWITCH</b>					

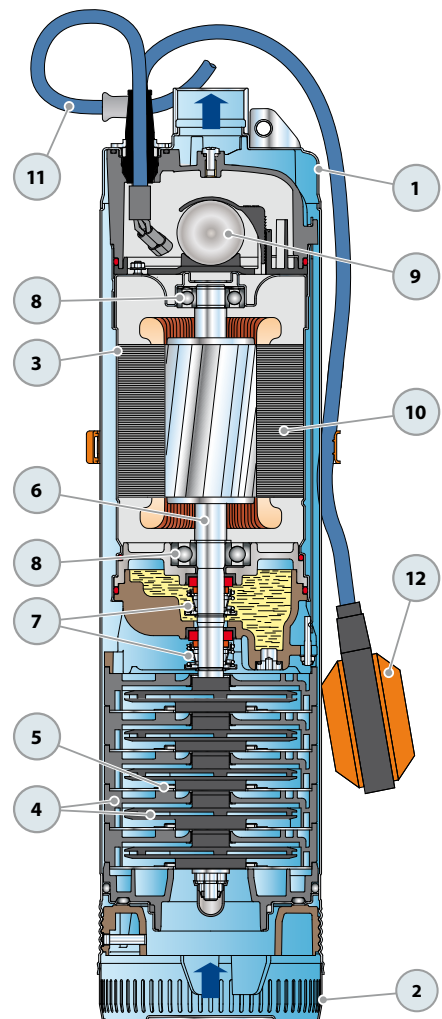

## DIMENSIONS AND WEIGHT

MODEL		PORT DN	N° STAGES	DIMENSIONS mm		kg	
Single-phase	Three-phase			Ø	h	1~	3~
NKm 2/1	-	1¼"	3	135	495	13.9	-
NKm 2/2	-		4		519	14.5	-
NKm 2/3	NK 2/3		5		573	16.3	15.2
NKm 2/4	NK 2/4		7		621	18.1	18.0
NKm 4/1	-		4		519	14.3	-
NKm 4/2	NK 4/2		5		573	16.2	15.2
NKm 4/3	NK 4/3		7		621	18.1	18.0

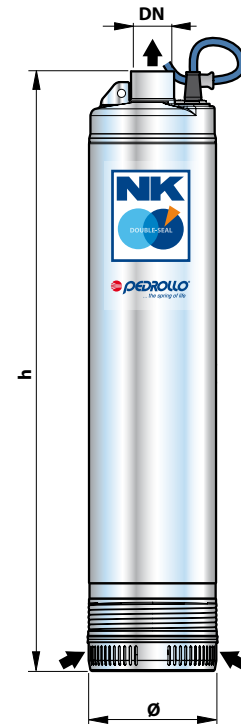

## ABSORPTION

MODEL	VOLTAGE (single-phase)		
	230 V	240 V	110 V
NKm 2/1	4.5 A	4.5 A	9.0 A
NKm 2/2	5.0 A	5.0 A	10.0 A
NKm 2/3	6.0 A	6.0 A	-
NKm 2/4	7.5 A	7.5 A	-
NKm 4/1	5.0 A	5.0 A	10.0 A
NKm 4/2	6.0 A	6.0 A	-
NKm 4/3	7.5 A	7.5 A	-

MODEL	VOLTAGE (three-phase)			
	230 V	400 V	240 V	415 V
NK 2/3	4.5 A	2.6 A	4.5 A	2.6 A
NK 2/4	5.2 A	3.0 A	5.2 A	3.0 A
NK 4/2	4.5 A	2.6 A	4.5 A	2.6 A
NK 4/3	5.2 A	3.0 A	5.2 A	3.0 A

## PALLETIZATION

MODEL		GROUPAGE				CONTAINER			
Single-phase	Three-phase	n° pumps	H (mm)	kg		n° pumps	H (mm)	kg	
				1~	3~			1~	3~
NKm 2/1	-	30	1015	434	-	60	1890	852	-
NKm 2/2	-	30	1015	452	-	60	1890	887	-
NKm 4/1	-	30	1015	425	400	40	1307	670	626
NKm 2/3	NK 2/3	25	869	425	400	40	1307	740	737
NKm 4/2	NK 4/2								
NKm 2/4	NK 2/4	25	869	469	467	40	1307	740	737
NKm 4/3	NK 4/3								

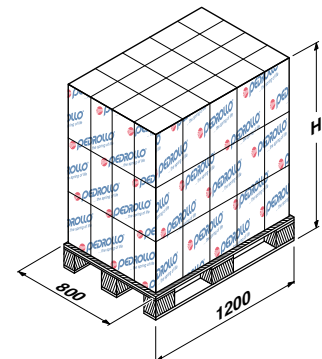

POS.	COMPONENT	CONSTRUCTION CHARACTERISTICS
1	EXTERNAL SLEEVE	Stainless steel AISI 304, complete with threaded delivery port in compliance with ISO 228/1
2	SUCTION FILTER	Stainless steel AISI 304
3	MOTOR SLEEVE	Stainless steel AISI 304
4	IMPELLERS AND DIFFUSERS	Noryl GFN2V
5	DIAPHRAGMS	Stainless steel AISI 304, complete with anti-wear ring
6	MOTOR SHAFT	Stainless steel EN 10088-3 - 1.4104
7	<b>TWO MECHANICAL SEALS SEPARATED BY AN OIL CHAMBER</b>	
	<i>Seal</i>	<i>Shaft</i>
	<i>Model</i>	<i>Diameter</i>
		<i>Position</i>
		<i>Stationary ring</i>
		<i>Rotational ring</i>
		<i>Elastomer</i>
	MG1-19	Ø 19 mm
	MG1-18 SIC	Ø 18 mm
		Motor side
		Pump side
		Silicon carbide
		Silicon carbide
		Graphite
		Silicon carbide
		NBR
		NBR
8	BEARINGS	6304 2RS - C3 / 6203 ZZ - C3
9	<b>CAPACITOR</b>	
	<i>Pump</i>	<i>Capacitance</i>
	<i>Single-phase</i>	<i>(230 V or 240 V)</i>
	NKm 2/5	35 µF 450 VL
	NKm 4/4	50 µF 450 VL
	NKm 4/5	50 µF 450 VL
10	<b>ELECTRIC MOTOR</b>	
	NKm: single-phase 230 V - 50 Hz. Windings up to 1.5 kW with built-in thermal overload protector.	
	⇒ The NKm4/5 2.2 kW pump is equipped with an external manual reset overload protector housed in the control box.	
	NK: three-phase 400 V - 50 Hz.	
	– Insulation: F class.	
	– Protection: IP X8.	
11	<b>POWER CABLE</b>	
	⇒ 20 metre long DRINCABLE® with removable connector for permanent immersion in drinking water	
12	<b>CONTROL BOX</b> (for single-phase versions)	
13	<b>FLOAT SWITCH</b>	

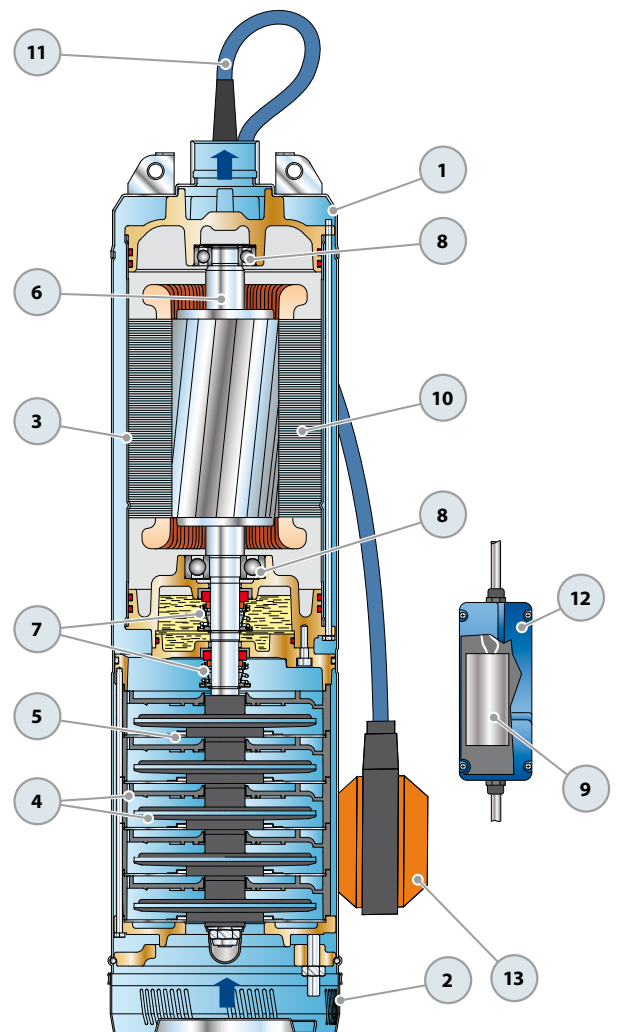

## DIMENSIONS AND WEIGHT

MODEL		PORT DN	N° STAGES	DIMENSIONS mm		kg	
Single-phase	Three-phase			Ø	h	1~	3~
NKm 2/5	NK 2/5	1¼"	6	153	612	26.7	23.8
NKm 4/4	NK 4/4		5		582	26.0	24.4
NKm 4/5	NK 4/5		7		642	30.5	28.0

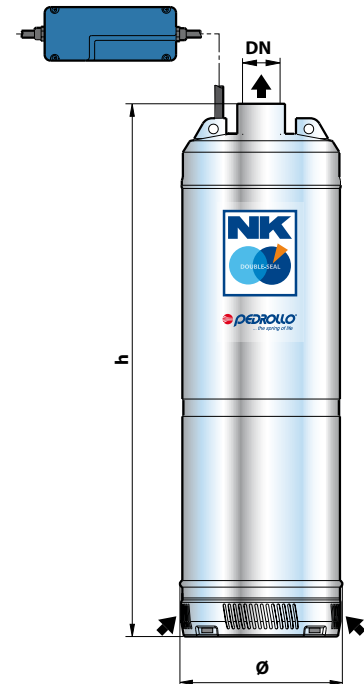

## ABSORPTION

MODEL	VOLTAGE (single-phase)	
	230 V	240 V
Single-phase		
NKm 2/5	9.0 A	9.0 A
NKm 4/4	9.5 A	9.5 A
NKm 4/5	14.0 A	14.0 A

MODEL	VOLTAGE (three-phase)			
	230 V	400 V	240 V	415 V
Three-phase				
NK 2/5	6.2 A	3.6 A	6.2 A	3.6 A
NK 4/4	6.2 A	3.6 A	6.2 A	3.6 A
NK 4/5	8.5 A	4.9 A	8.5 A	4.9 A

## PALLETIZATION

MODEL		GROUPAGE				CONTAINER			
Single-phase	Three-phase	n° pumps	H (mm)	kg		n° pumps	H (mm)	kg	
				1~	3~			1~	3~
NKm 2/5	NK 2/5	20	1100	551	493	40	2060	1085	969
NKm 4/4	NK 4/4	20	1100	537	505	40	2060	1058	993
NKm 4/5	NK 4/5	20	1100	627	576	40	2060	1237	1136

