

8
PCS

NEW
NUEVO
NOVO



Electrician screwdriver set
VDE



*Bandeja de destornilladores
electricista VDE*

Conjunto de chaves de para-
fuso de electricistas VDE

Art.

4900-63B

↕ L1 402 × L2 173 × L3 48 mm

	Art. 3132-1	2.5 × 75 mm
	Art. 3132-4	4.0 × 100 mm
	Art. 3132-5	5.5 × 125 mm
	Art. 3132-6	6.5 × 150 mm
	Art. 3135-0	PH0 × 60 mm
	Art. 3135-1	PH1 × 80 mm
	Art. 3135-2	PH2 × 100 mm
	Art. 2138	100-250 V

   **1000 V**
IEC 60900

10
PCS

NEW
NUEVO
NOVO



Electrician TX screwdriver set
VDE

with bore hole at the tip, for normal TX
screws and tamperproof TX screws

*Bandeja de destornilladores
TX electricista VDE*

*con punta perforada, para tornillos con y
sin punta de seguridad*

Conjunto de chaves TX de
electricistas VDE

com furo, para parafusos normais e de
segurança

Art.

4900-64B

↕ L1 402 × L2 173 × L3 48 mm

	Art. 3133-06	T6 × 100 mm
	Art. 3133-07	T7 × 100 mm
	Art. 3133-08	T8 × 100 mm
	Art. 3133-10	T10 × 100 mm
	Art. 3133-15	T15 × 100 mm
	Art. 3133-20	T20 × 100 mm
	Art. 3133-25	T25 × 125 mm
	Art. 3133-27	T27 × 125 mm
	Art. 3133-30	T30 × 150 mm
	Art. 3133-40	T40 × 175 mm

   **1000 V**
IEC 60900

10
PGS

NEW
NUEVO
NOVO

Electrician hex key wrench and
hex screwdriver set VDE

*Bandeja llaves y
destornilladores hexagonales
machos electricista VDE*

Conjunto de chaves em
"L" e chaves de parafuso
sextavadas de electricistas
VDE

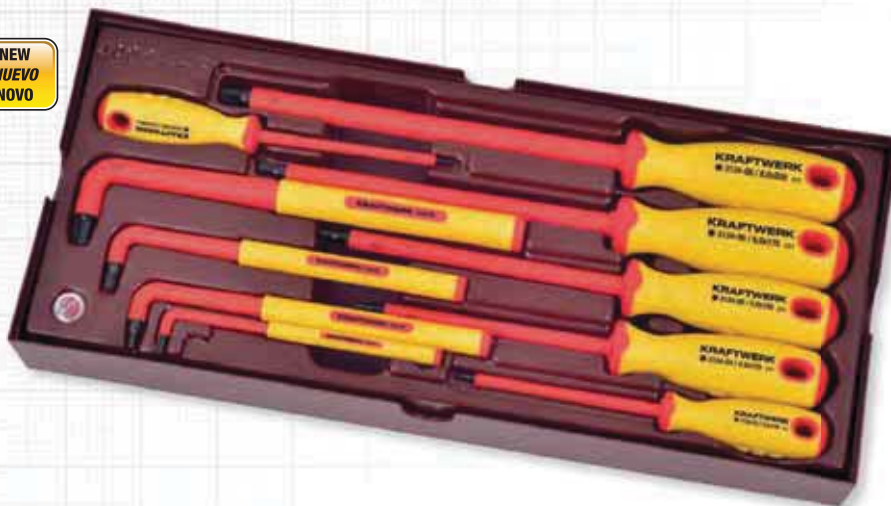

Art.

4900-65B

↔ L1 402 × L2 173 × L3 48 mm

	● Art. 3134-025	2.5 × 100 mm
	Art. 3134-03	3.0 × 100 mm
	Art. 3134-04	4.0 × 125 mm
	Art. 3134-05	5.0 × 150 mm
	Art. 3134-06	6.0 × 175 mm
	Art. 3134-08	8.0 × 200 mm

	● Art. 3136-03	3.0 × 126 mm
	Art. 3136-04	4.0 × 160 mm
	Art. 3136-05	5.0 × 160 mm
	Art. 3136-06	6.0 × 200 mm



1000 V
IEC 60900

6
PGS

NEW
NUEVO
NOVO

Electrician pliers and cutting
tool set VDE

*Bandeja alicates y
herramientas de corte
electricista VDE*

Conjunto de alicates e de
ferramentas de corte de
electricistas VDE



ergokraft

Art.

4900-67B

↔ L1 402 × L2 173 × L3 48 mm

	Art. 3281-180V	180 mm
	DIN ISO 5746	

	Art. 3282-160V	160 mm
	DIN ISO 5749	

	Art. 3285-200V	200 mm
	DIN ISO 5745	

	Art. 2251V	
---	------------	--

	Art. 3321V	
---	------------	--

	4pcs. Art. 3321-4V	
---	--------------------	--



1000 V
IEC 60900

HYBRID

4
PCS

Electrician pliers tray VDE
Bandeja alicates electricista VDE

Conjunto de alicates de electricistas VDE

Art.

4900-43B

↕ L1 402 × L2 173 × L3 48 mm



Art. 4211-180 180 mm **K C H**
DIN ISO 5746



Art. 4212-160 160 mm **K C H**
DIN ISO 5749



Art. 4215-205 200 mm **C H**
DIN ISO 5745



Art. 4219-160 160 mm
DIN ISO 5232

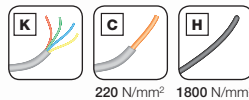

Made in Germany



1000 V
IEC 60900

4
PCS

Electrician pliers tray VDE
Bandeja alicates electricista VDE

Conjunto de alicates de electricistas VDE

Art.

4900-42B

↕ L1 402 × L2 173 × L3 48 mm

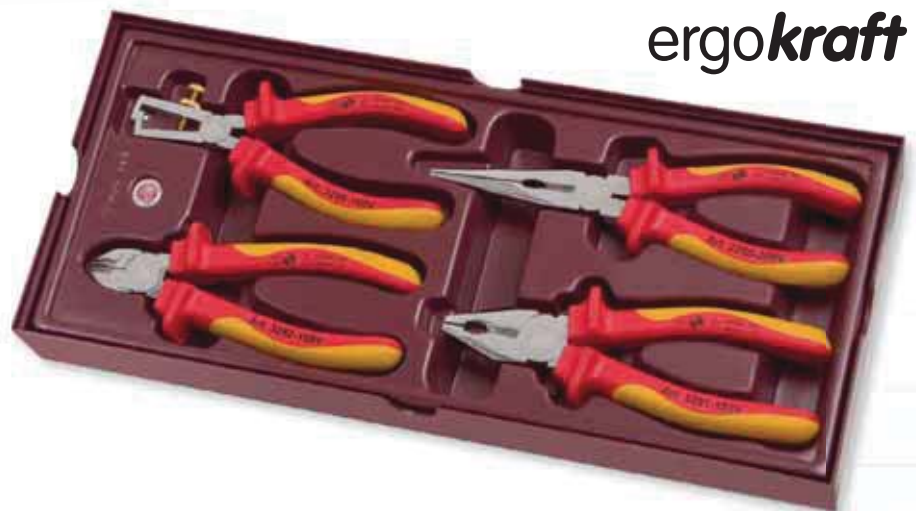

ergokraft



Art. 3281-180V 180 mm
DIN ISO 5746



Art. 3282-160V 160 mm
DIN ISO 5749



Art. 3285-200V 205 mm
DIN ISO 5745



Art. 3289-160V 160 mm
DIN ISO 5232



1000 V
IEC 60900

4
PCS

NEW
NUEVO
NOVO

HIGHTECH3C

Industrial pliers tray
with 3 component handles

*Bandeja alicates industriales
con mangos de 3 componentes*

Conjunto de alicates
industriais
com punhos de 3 componentes



Made in Germany

Art.
4900-33B

↔ L1 402 × L2 173 × L3 48 mm



Art. 4271-180
DIN ISO 5746

180 mm **K C H**



Art. 4272-160
DIN ISO 5749

160 mm **K C H**



Art. 4275-205
DIN ISO 5745

205 mm **C H**



Art. 4279-160
DIN ISO 5232

160 mm



220 N/mm² 1800 N/mm²

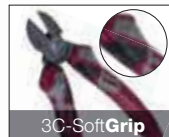

3C-SoftGrip



ShockResistance



TitaniumFinish

4
PCS

Pliers tray
Bandeja alicates
Conjunto de alicates

ergokraft



Art.
4900-07B

↔ L1 402 × L2 173 × L3 48 mm



Art. 3281-180
DIN ISO 5746

180 mm



Art. 3282-160
DIN ISO 5749

160 mm



Art. 3285-200
DIN ISO 5745

200 mm



Art. 3289-160
DIN ISO 5232

160 mm



5
PCS

NEW
NUEVO
NOVO

Universal pliers tray
Bandeja universal alicates
Conjunto universal de alicates



Art.	
4900-57B1	4224-250
4900-57B2	4223-240
4900-57B3	4222-250

↔ L1 402 × L2 173 × L3 48 mm

4900-57B1 / Art. 4224-250

Made in Germany **HIGHTECH**

4GRIP

50 mm

DIN ISO + 40%

250 mm

drag&drop

Made in Germany Art. 4276-205 205 mm
DIN ISO 5745
HIGHTECH-KIC

Art. 3292-250 max. 250/10"
CrMo

Art. 3290-230 230 mm
ergokraft
1.5 - 6 mm² 1.5 - 4.6 mm²

VICTORINOX



4900-57B2 / Art. 4223-240

Made in Germany

50 mm

DIN ISO 8976

240 mm

Made in Germany Art. 4276-205 205 mm
DIN ISO 5745
HIGHTECH-KIC

Art. 3292-250 max. 250/10"
CrMo

Art. 3290-230 230 mm
ergokraft
1.5 - 6 mm² 1.5 - 4.6 mm²

VICTORINOX



4900-57B3 / Art. 4222-250

Made in Germany

50 mm

DIN ISO 8976

250 mm

Made in Germany Art. 4276-205 205 mm
DIN ISO 5745
HIGHTECH-KIC

Art. 3292-250 max. 250/10"
CrMo

Art. 3290-230 230 mm
ergokraft
1.5 - 6 mm² 1.5 - 4.6 mm²

VICTORINOX

4
PGS

Universal pliers tray
Bandeja universal alicates
Conjunto universal de alicates



Art.

4900-08B

↔ L1 402 × L2 173 × L3 48 mm

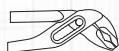

Art. 2221-250 250 mm
DIN ISO 8976



Art. 2216-200 200 mm
DIN ISO 9243



Art. 2262-07 7-1/2" 195 mm

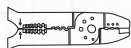

Art. 2225 240 mm 1.5 - 6 mm² 1.5 - 4.6 mm²

4
PGS

Circlips pliers tray
Bandeja alicates arandelas
Conjunto de alicates de freios



Art.

4900-09B

↔ L1 402 × L2 173 × L3 48 mm

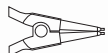

Art. 2212-A2 A2
DIN ISO 5254A



Art. 2213-A21 A21
DIN ISO 5254B

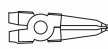

Art. 2214-J2 J2
DIN ISO 5256C

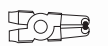

Art. 2215-J21 J21
DIN ISO 5256D

COMPLETO Serie 4900

ergokraft

5
PCS

Adjustable wrench and pliers tray

Bandeja llaves ajustables y alicates

Conjunto de chaves crescentes e de alicates



Art.

4900-21B

↔ L1 402 × L2 173 × L3 48 mm



ergokraft

Art. 3572	150 mm / 6"	○ 0-13 mm
Art. 3573	200 mm / 8"	○ 0-25 mm
DIN 3117 / ISO 6787		



ergokraft M2

Art. 2243	250 mm	HRC 58-60
-----------	--------	-----------



Art. 3292-175	175 mm / 7"	CrMo
---------------	-------------	------



Art. 3292-150	150 mm / 6"	CrMo
---------------	-------------	------

11
PCS

Files tray

Bandeja limas

Conjunto de limas



ergokraft

Art.

4900-10B

↔ L1 402 × L2 173 × L3 48 mm



Art. 4320-1	320 mm	
DIN 7261		



Art. 4320-2	320 mm
DIN 7261	



Art. 4320-3	320 mm
DIN 7261	



Art. 4320-4	320 mm
DIN 7261	



Art. 4320-5	320 mm
DIN 7261	

|| ○ □ ◁ ▽ Art. 4321

22
PGS





Cutting tool tray
Bandeja herramientas corte
Conjunto de ferramentas de corte



Art.
4900-11B

↔ L1 402 × L2 173 × L3 48 mm



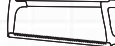

ergokraft

-  **ergokraft** Art. 3310 9 mm
-  12x Art. 3313 9 mm
-  **ergokraft** Art. 3312 18 mm
-  5x Art. 3314 18 mm
-  Art. 3305 300 mm

-  **ergokraft** Art. 3308-1
-  Art. 3316-24 300 mm
- HSS-Bimetal**
-  **ergokraft** Art. 2240

11
PGS

Striking tool tray
Bandeja herramientas golpe
Conjunto de martelos e punções

Art.		
4900-56B	Art. 2305	500 g
4900-66B	Art. 2319	500 g

↔ L1 402 × L2 173 × L3 48 mm

NEW
NUEVO
NOVO











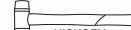

4900-56B / Art. 2305

4900-56B / Art. 2305



4900-66B / Art. 2319



-  Art. 2336 Ø 35 mm
-  Art. 3380-18 18 mm
-  Art. 3380-22 22 mm
- DIN 6451/53**
-  Art. 1350-2 2 mm
-  Art. 1350-3 3 mm
-  Art. 1350-4 4 mm
-  Art. 1350-5 5 mm
-  Art. 1350-6 6 mm
-  Art. 1350-8 8 mm
- DIN 6450 Form C**
-  Art. 1358-2 No. 2
- DIN 7250**

9
PCS









Measuring tool tray
Bandeja herramienta medición
Conjunto de medição

Art.

4900-12B

↔ L1 402 × L2 173 × L3 48 mm



	Art. 4701-0519	5 m × 19 mm
	Art. 2970	150 mm × 0.05 mm 6" × 1/128"
	Art. 2975	0-25 mm × 0.01 mm
	Art. 2976	300 mm × 28 mm
	Art. 2977	200 mm
	Art. 2978	100 mm × 70 mm
	Art. 2974	0.05-0.1-0.15-0.2-0.3-0.4-0.5-0.6-0.7-0.8 mm
	Art. 3196	130-630 mm / 2000 g
	Art. 4996	

HSS-G **40**
PCS







Drill bit and tap + die tray
Bandeja brocas-machos-terrajás
Conjunto de ferramentas de corte

Art.

4900-34B

↔ L1 402 × L2 173 × L3 48 mm



	Art. 23030	M3		Art. 11904	1-1.5-2-2.5-3-3.5-4
	Art. 23040	M4		DIN 338 N	4.5-5-5.5-6-6.5-7-7.5
	Art. 23050	M5			8-8.5-9-9.5-10 mm
	Art. 23060	M6			
	Art. 23080	M8			
	Art. 23100	M10			
	Art. 23120	M12			
	Art. 24200	0.25-6 mm / 60°		Art. 11033	3.3 mm
	Art. 24015	M2-M12		Art. 11042	4.2 mm
	DIN 1814			Art. 11068	6.8 mm
	Art. 24110	M3-M10		Art. 11102	10.2 mm
	DIN 1814			DIN 338 N	
				Art. 25030	M3
				Art. 25040	M4
				Art. 25050	M5
				Art. 25060	M6
				Art. 25080	M8
				Art. 25100	M10
				Art. 25120	M12
				DIN 371	

HSS-G **42**
PCS

NEW
NUEVO
NOVO

Drill bit and tap + die tray
Bandeja brocas-machos-terrajás

Conjunto de ferramentas de corte



Art.

4900-59B

↔ L1 402 × L2 173 × L3 48 mm



Art. 26030 M3
Art. 26040 M4
Art. 26050 M5
Art. 26060 M6
Art. 26080 M8
Art. 26100 M10
Art. 26120 M12
DIN / ISO 261

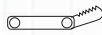

Art. 24200 0.25-6 mm / 60°



Art. 24010 M3-M12
DIN 225



Art. 24015 M2-M12
DIN 1814



Art. 24110 M3-M10
DIN 1814



Art. 11904 1-1.5-2-2.5-3-3.5-4
DIN 338 N 4.5-5-5.5-6-6.6-7-7.5
8-8.5-9-9.5-10 mm



Art. 11033 3.3 mm
Art. 11042 4.2 mm
Art. 11068 6.8 mm
Art. 11102 10.2 mm
DIN 338 N



Art. 25030 M3
Art. 25040 M4
Art. 25050 M5
Art. 25060 M6
Art. 25080 M8
Art. 25100 M10
Art. 25120 M12
DIN 371



Art. 3240S Ø 0.5 mm

HSS-G **77**
PCS

Threaded coil-insert repair tray

Bandeja reparación roscas

Conjunto de reparação de roscas



Art.

4900-51B

↔ L1 402 × L2 173 × L3 48 mm



M4-M12, M6-M20
3/18"-1/2", 1/4"-3/4"



M5×0.8, M6×1.0,
M8×1.25, M10×1.5,
M12×1.75, M14×1.25

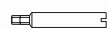

M5×0.8, M6×1.0,
M8×1.25, M10×1.5,
M12×1.75, M14×1.25



M5×0.8, M6×1.0,
M8×1.25, M10×1.5,
M12×1.75, M14×1.25



215-640 mm

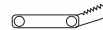

0.5-1.75 mm







16 M5-0.8
12 M6-1.0
10 M8-1.25
6 M10-1.5
5 M12-1.75
4 M14-1.25

COMPLETO Serie 4900







HSS **16**
bimetal **PCS**
M42+8%Co

Hole saw tray
Bandeja coronas perforadas
Conjunto de serras cranianas

Art.	
4900-39B	
4900-39BS	 

↕ L1 402 × L2 173 × L3 48 mm



	Art. 19001		Art. 19005	14-30 mm / 3/8"
	Art. 19002		Art. 19006	32-76 mm / 7/16"
	Art. 19003			300 mm / 3/8"
	Art. 19190	19 mm	Art. 19380	38 mm
	Art. 19200	20 mm	Art. 19440	44 mm
	Art. 19220	22 mm	Art. 19510	51 mm
	Art. 19250	25 mm	Art. 19570	57 mm
	Art. 19290	29 mm	Art. 19680	68 mm
	Art. 19320	32 mm	Art. 19760	76 mm
	Art. 19350	35 mm		



Workshop LED lights tray
Bandeja lámparas LED taller
Conjunto de gambiarras para oficina

NEW
NUEVO
NOVO

8
PCS

LIGHT

Art.	LIGHT	Art.
4900-52B	32022 + 32001UV + 32051	
4900-53B	32022 + 32001 + 32051	

↕ L1 402 × L2 173 × L3 48 mm



Art. 32022
↕ 285 mm, Ø 40 mm



4900-52B / Art. 32001UV
4900-53B / Art. 32001
↕ 250 mm, Ø 36 mm



Art. 32051
↕ 145 mm, Ø 28 mm

3W COB LED
80-100 LUX
170-200 lm
* Chip On Board / Chip en placa

Li-Ion 3.7 V
(4000 mAh)





4900-52B / Art. 32001UV
18 + 4 UVLED
500 LUX (1m) + 120 LUX (1m)

4900-53B / Art. 32001
18 + 4 LED
500 LUX (1m) + 120 LUX (1m)



GREE 3 W
1 LED
80 lm

 0-200 m ZOOM



100-240 V / 50/60 Hz  12-24 V 

4
PCS

NEW
NUEVO
NOVO

Photo-/video-endoscope tray
Bandeja foto-/video-endoscopio
Conjunto video-endoscópio



Art.	Ø mm	L	
4900-45B-0391	3.9	1 m	flex
4900-45B-0393	3.9	3 m	flex
4900-45B-0550*	5.5	1 m	mem
4900-45B-0551*	5.5	1 m	flex
4900-45B-0553*	5.5	3 m	flex
4900-45B-0800	8.0	1 m	mem
4900-45B-0801	8.0	1 m	flex
4900-45B-1200	12.0	1 m	mem

↕ L1 402 × L2 173 × L3 48 mm



↕ L1 94 × L2 78 × L3 10 mm

Display 3.5" / 89 mm TFT
640 × 480 pixel
16.7 Mio. Colors / 30 bps

Video PAL / NTSC

Sensor CMOS

Battery Li-Polymer-Akku 3.7 V 2000 mAh
(100~240 V / 50-60 Hz)

Memory SD Card 2GB (max. 8GB)

IP67

flex = flexible / flexible / flexível
mem = rigid / rígido / rígido

Longer cables on request
Cables más largos bajo pedido
Cabos mais longos, a pedido

inklusive / inclus / incluso:

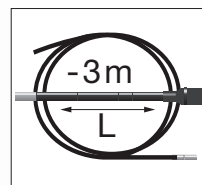
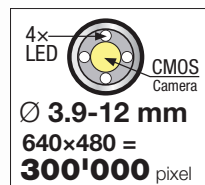
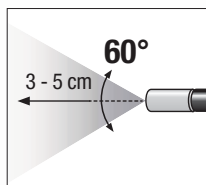

Option / Opcional / Opcional :

4900-45B-0550 / 4900-45B-0551 / 4900-45B-0553

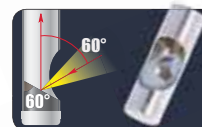
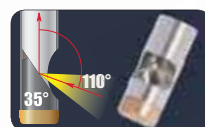

Special tray for small parts
Bandeja piezas pequeñas
Bandeja vazia para pequenas
peças

Art.

4900-37B

↕ L1 402 × L2 173 × L3 48 mm



ABS injection tray
empty
Bandeja en ABS
vacia
Bandeja em ABS
vazia

Art.

4900E

↕ L1 402 × L2 173 × L3 48 mm



ABS blow mould case
for COMPLETEO trays, empty

Estuche en ABS

para bandejas COMPLETEO, vacío

Mala em ABS

para conjuntos COMPLETEO, vazia

Art.

4900K

↔ L1 421 × L2 200 × L3 68 mm



Tool carrying case

Practical and solid with carrying belt and 4 compartments at the side and big top-compartment. Space for 6 COMPLETE-trays.

Maletín para herramientas
práctica y resistente, 4 compartimentos laterales y 1 gran compartimento superior. Espacio para 6 bandejas COMPLETE.

Mala para conjuntos

Prática e sólida, com 4 compartimentos frontais e um compartimento grande no topo. Espaço para 6 bandejas COMPLETE.

Art.

4900T

↔ L1 450 × L2 360 × L3 230 mm



Tool carrying case

with 4 empty trays

Maletín para herramientas
con 4 bandejas vacías

Mala para conjuntos
com 4 bandejas vazias



Art.

4900TS

4 × 4900E

↔ L1 450 × L2 360 × L3 230 mm



Video
[KRAFTWERKtools.com/video/4900T](https://www.KRAFTWERKtools.com/video/4900T)

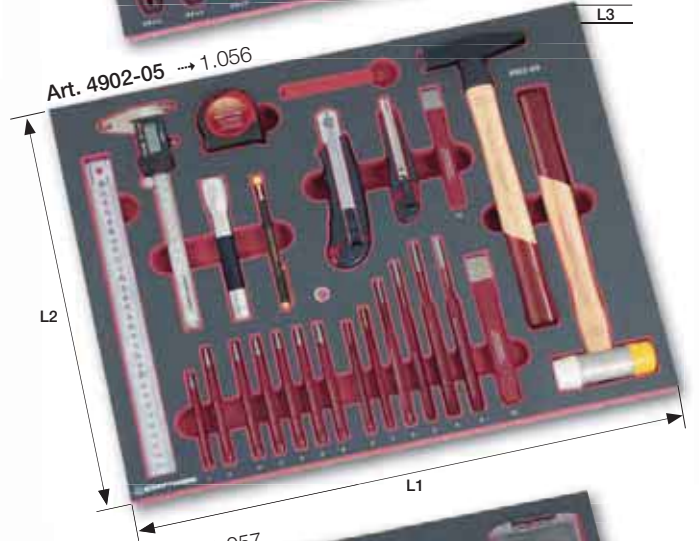
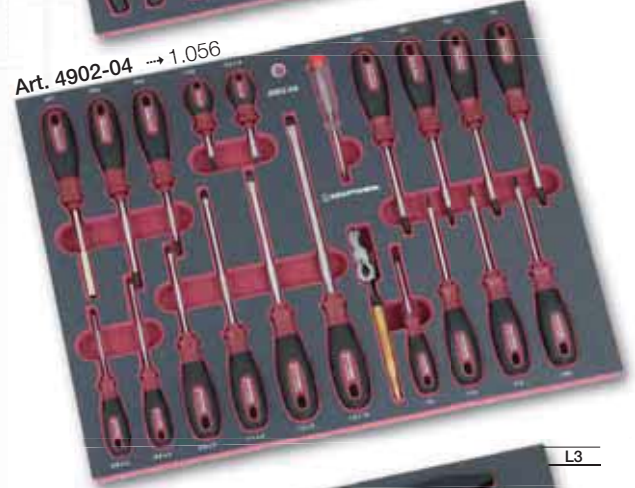
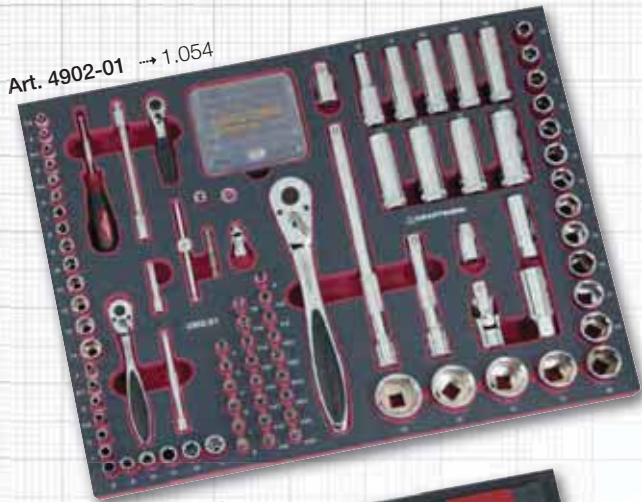

309
PCS



Tool-assortment

with professional tools, shakeproof imbedded in 6 drawers with special high density soft foam (EVA) inserts with a durable hard top lamination which can be well cleaned.

Surtido de herramientas profesionales

encastradas en 6 bandejas especiales de espuma de alta densidad (EVA) con un recubrimiento superior de plástico duro y resistente para un buen mantenimiento y limpieza.

Conjunto de ferramentas profissionais

colocadas em 6 gavetas inseridas em espuma de alta densidade (EVA) com revestimento superior que prolonga a duração e permite manter limpo.

Art.	
4917	HIGHTECH / KRAFTWERK RACING

↕ L1 527 × L2 407 × L3 30 mm



Video
[KRAFTWERKtools.com/video/4917](https://www.kraftwerktools.com/video/4917)

COMPLETO EVA Serie 4902

4917



309
PCS

NEW
NUEVO
NOVO

Tool-assortment with tool-cabinets
Composición de herramientas con carros
Sortido de ferramentas com carros





3908



3909



2907

Art.			
3908-4917	3908	8	1.003
3909-4917	3909	11	1.004
2907-4917	2907	7	1.007



Socket wrench set
Bandeja llaves vasos
Conjunto de chaves de caixa

Art.
4902-01

↔ L1 527 × L2 407 × L3 30 mm

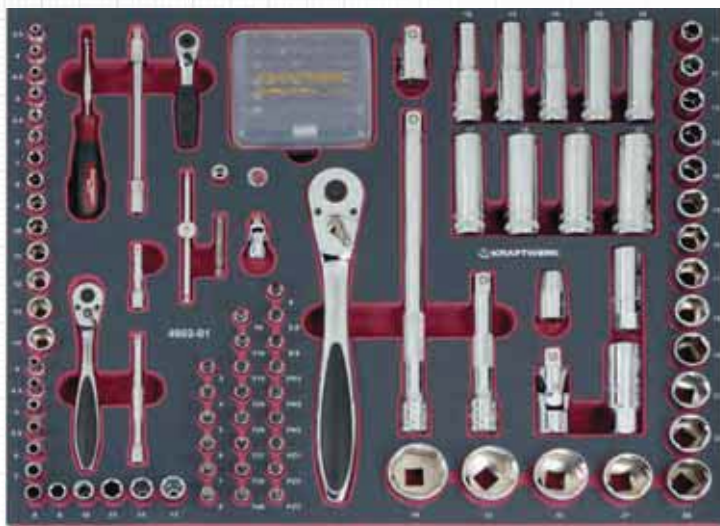

- | | | | | | |
|--|----|--|--|----|--|
| | 14 | 3.5-4-4.5-5-5.5-6-7-8
9-10-11-12-13-14 mm | | 17 | 10-11-12-13-14-15-16-17-18
19-21-22-24-27-30-32-34 mm |
| | 12 | 4-4.5-5-5.5-6-7-8-9
10-11-12-13 mm | | 9 | 10-13-14-15-16-17-18
19-22 mm |
| | 3 | 4-5.5-6.5 mm | | 2 | 16 mm / 21 mm |
| | 3 | PH 1-2-3 | | | □ 1/2" □ 1/2" |
| | 3 | PZ 1-2-3 | | 2 | 125 mm / 250 mm |
| | 8 | T8-T10-T15-T20
T25-T27-T30-T40 | | | □ 3/8" □ 1/2" |
| | 6 | 3-4-5-6-7-8 mm | | | □ 1/2" □ 5/16" |
| | | □ 1/4" □ 1/4" | | 60 | Art. 4020B |
| | | □ 1/4" □ 1/4" | | | |
| | 2 | 50 mm / 100 mm | | | |
| | | 150 mm | | | |
| | | 105 mm | | | |
| | | □ 1/4" □ 1/4" | | | |
| | | □ 1/4" □ 1/4" | | | |

- | | | |
|--|----|------------|
| | 72 | Art. 3799 |
| | 60 | Art. 4000B |

- | | | |
|--|---|------------------------------------|
| | 6 | 4-4.5-5.5-6-6.5-8 mm |
| | 4 | PH 1-2-3-4 |
| | 4 | PZ 1-2-3-4 |
| | 8 | T8-T10-T15-T20-T25-T27-T30-T40 |
| | 8 | T8-T10-T15-T20-T25-T27-T30-T40 |
| | 6 | 3-4-5-6-7-8 mm |
| | 6 | 2-2.5-3-4-5-6 mm |
| | 6 | 5/64"-3/32"-7/64"-1/8"-9/64"-5/32" |
| | 3 | Nos. 6-8-10 |
| | 4 | Nos. 1-2-3-4 |
| | 4 | Nos. 4-6-8-10 |

1/4" 1/4" 1/4" 1/4"



GLOBALBIT-Box
Art. 3777
101 × 90 × 32 mm

61
PCS

45
PCS

Spanner and torque wrench set

Bandeja llaves combinadas y llave dinamométrica

Conjunto de chaves de bocaneta e chave dinamométrica

Art.
4902-02

↔ L1 527 × L2 407 × L3 30 mm



Art. 3235 1/2" 40-200 Nm / 30-150 Lb.ft

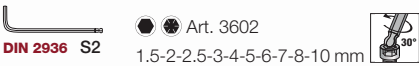

Art. 3602
1.5-2-2.5-3-4-5-6-7-8-10 mm

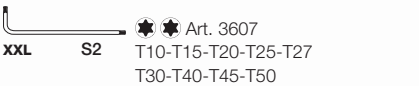

Art. 3607
T10-T15-T20-T25-T27
T30-T40-T45-T50

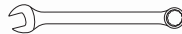

DIN 3113

Art. 3505	5.5 mm	Art. 3511	11 mm	Art. 3517	17 mm	Art. 3523	23 mm
Art. 3506	6 mm	Art. 3512	12 mm	Art. 3518	18 mm	Art. 3524	24 mm
Art. 3507	7 mm	Art. 3513	13 mm	Art. 3519	19 mm	Art. 3527	27 mm
Art. 3508	8 mm	Art. 3514	14 mm	Art. 3520	20 mm	Art. 3530	30 mm
Art. 3509	9 mm	Art. 3515	15 mm	Art. 3521	21 mm	Art. 3532	32 mm
Art. 3510	10 mm	Art. 3516	16 mm	Art. 3522	22 mm		



ergokraft

DIN 3117 / ISO 6787

Art. 3572 150 mm / 6"
Art. 3573 200 mm / 8"

13
PCS

Pliers set

Bandeja alicates

Conjunto de alicates

Art.
4902-03

↔ L1 527 × L2 407 × L3 30 mm



Art. 3281-180 180 mm
DIN ISO 5746

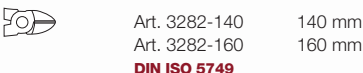

Art. 3282-140 140 mm
Art. 3282-160 160 mm
DIN ISO 5749

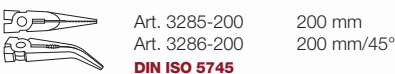

Art. 3285-200 200 mm
Art. 3286-200 200 mm/45°
DIN ISO 5745

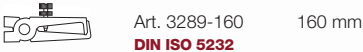

Art. 3289-160 160 mm
DIN ISO 5232



Art. 2221-250 250 mm
DIN ISO 8976



Art. 2240 180 mm
ergokraft



Art. 2212-A2 A2
DIN ISO 5254A



Art. 2213-A21 A21
DIN ISO 5254B



Ø 19-60 mm



Art. 2214-J2 J2
DIN ISO 5256C



Art. 2215-J21 J21
DIN ISO 5256D



Art. 3290-230 230 mm
1.5 - 6 mm² 1.5 - 4-6 mm²

S2
quality

21
PCS









Screwdriver set
Bandeja destornilladores
Conjunto de chaves de parafusos

Art.
4902-04

↔ L1 527 × L2 407 × L3 30 mm



ergokraft

- | | | | | | |
|--|-------------------------|---|------------------|---|-----------|
|  S2 | Art. 4110-1 0.6 × 3 mm |  S2 + | Art. 4117-2 PH2 |  | Art. 2138 |
| | Art. 4110-2 0.8 × 4 mm |  S2 * | Art. 4125-08 T8 |  | 100-250 V |
| | Art. 4110-3 1.0 × 5 mm | | Art. 4125-10 T10 |  | Art. 2139 |
| | Art. 4110-4 1.1 × 6 mm | | Art. 4125-15 T15 | | 12 V |
| | Art. 4110-5 1.2 × 8 mm | | Art. 4125-20 T20 | | |
| | Art. 4110-6 1.6 × 10 mm | | Art. 4125-25 T25 | | |
| | | | Art. 4125-27 T27 | | |
| | | | Art. 4125-30 T30 | | |
| | | | Art. 4125-40 T40 | | |
|  S2 + | Art. 4115-1 PH1 |  S2 | Art. 4128 1/4" | | |
| | Art. 4115-2 PH2 | | | | |
|  S2 | Art. 4112-2 1.1 × 6 mm | | | | |

41
PCS















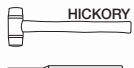

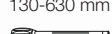



Striking/cutting and measuring tool set
Bandeja herramientas golpe/medición
Conjunto de percussão e de medição/corte

Art.
4902-05

↔ L1 527 × L2 407 × L3 30 mm



ergokraft

- | | | | | | | | | |
|--|-------------|---------|---|--------------|---|------------|---|------------------|
|  HICKORY
DIN 1041 | Art. 2303 | 300 g |  Art. 1355-2 | 2 mm |  Art. 3196 | 130-630 mm |  Art. 3312 | 18 mm |
|  HICKORY | Art. 2336 | Ø 35 mm |  DIN 6458 | 3 mm |  Art. 4996 | |  5x | Art. 3314 |
|  DIN 6450 Form C | Art. 1350-2 | 2 mm | Art. 1355-4 | 4 mm |  Art. 2976 | |  | Art. 2972 |
| | Art. 1350-3 | 3 mm | Art. 1355-5 | 5 mm |  Art. 3310 | 9 mm |  | DIGITAL |
| | Art. 1350-4 | 4 mm | Art. 1355-6 | 6 mm |  Art. 3313 | 9 mm |  | 150 mm × 0.01 mm |
| | Art. 1350-5 | 5 mm |  DIN 7250 | No. 1 |  12x | Art. 3313 |  | 6" × 0.0005" |
| | Art. 1350-6 | 6 mm |  DIN 6451/53 | Art. 3380-18 | | |  | Art. 4700-0316 |
| | Art. 1350-8 | 8 mm | | Art. 3380-22 | | | | 3 m × 16 m |

35
PCS

File, saw and drill bit set
Bandeja limas y brocas
Conjunto de limas, de serras e de brocas

Art.
4902-06

↔ L1 527 × L2 407 × L3 30 mm



-  Art. 4320-1 320 mm
DIN 7261
-  Art. 4320-2 320 mm
DIN 7261
-  Art. 4320-3 320 mm
DIN 7261
-  Art. 4320-4 320 mm
DIN 7261
-  Art. 4320-5 320 mm
DIN 7261

 Art. 4321

 Art. 3305
300 mm

 Art. 3308-1

 Art. 3316-24
HSS-Bimetall 300 mm

 Art. 11904 1-1.5-2-2.5-3
DIN 338 N 3.5-4-4.5-5-5.5
6-6.5-7-7.5-8
8.5-9-9.5-10 mm

 Art. 5433 3-30 mm CU

 Art. 5470 Ø 4-40 cm

12
PCS

T-type universal socket set
extra long
Bandeja muletillas con vaso
extra largo
Conjunto de chaves de caixa em "T" longa

Art.
4902-07

↔ L1 527 × L2 407 × L3 30 mm

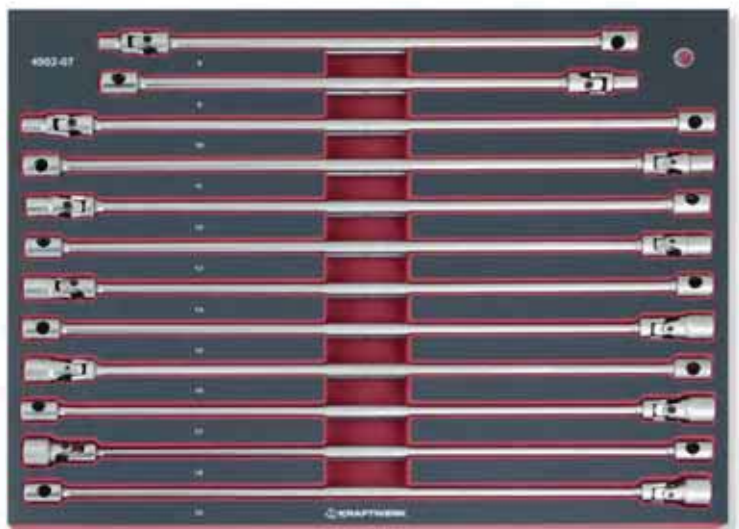

XXL

DIN 896 / ISO 2236, 1085

- Art. 2592-08 8 mm
- Art. 2592-09 9 mm
- Art. 2592-10 10 mm
- Art. 2592-11 11 mm
- Art. 2592-12 12 mm
- Art. 2592-13 13 mm

- Art. 2592-14 14 mm
- Art. 2592-15 15 mm
- Art. 2592-16 16 mm
- Art. 2592-17 17 mm
- Art. 2592-18 18 mm
- Art. 2592-19 19 mm





21
PCS

NEW
NUEVO
NOVO

Heavy duty socket wrench set
with fine teeth ratchet handle with socket
quick release function and extension bars
with locking system

**Estuche industrial de llaves
de vaso**

con carraca dentado fino con función
de extracción rápida y alargadera con
sistema de bloqueo

**Jogo de chaves de caixa
"Heavy duty"**

com roquete de dentes finos com meca-
nismo de ejeção de chaves e extensões
com sistema de segurança



Art.

4902-08

↔ L1 527 × L2 407 × L3 40 mm



16 19-21-22-23-24-26-27-29-30
32-35-36-38-41-46-50 mm

3 100-200-400 mm

460 mm



22
PCS

Heavy duty socket wrench set
with digital torque adapter

**Estuche industrial de llaves
de vaso**

con adaptador dinamométrico
electrónico

**Jogo de chaves de caixa
"Heavy duty"**

com adaptador electrónico torque



Art.

4902-080

4081-34

4902-081

4081-341

↔ L1 527 × L2 407 × L3 40 mm

NEW
NUEVO
NOVO



16 19-21-22-23-24-26-27-29-30
32-35-36-38-41-46-50 mm

3 100-200-400 mm

460 mm



4902-080 / Art. 4081-34

Art. 4081-34
100-500 Nm (± 2%) / 73.8-369 Lb.ft
kg-m / kg-cm / lb-in / ft-lbs

4902-081 / Art. 4081-341

Art. 4081-341
200-1000 Nm (± 2%) / 147.6-738 Lb.ft
kg-m / kg-cm / lb-in / ft-lbs



21
PGS

NEW
NUEVO
NOVO

Heavy duty socket wrench set
with extensible/telescope fine teeth
ratchet handle with socket quick release
function and extension bars with locking
system

Estuche industrial de llaves de vaso

con carraca dentado fino con mango
telescopico/extensible con función de
extracción rápida y alargadera con
sistema de bloqueo

Jogo de chaves de caixa "Heavy duty"

com roquete extensível de dentes finos
com mecanismo de ejeção de chaves
e extensões com sistema de segurança

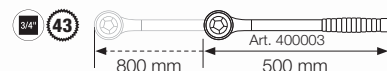

16 19-21-22-23-24-26-27-29-30
32-35-36-38-41-46-50 mm

3 100-200-400 mm

460 mm

Art.

4902-09

↔ L1 527 × L2 407 × L3 40 mm



22
PGS



Heavy duty socket wrench set
with digital torque adapter

Estuche industrial de llaves de vaso

con adaptador dinamométrico
electrónico

Jogo de chaves de caixa "Heavy duty"

com adaptador electrónico torque



Art.



4902-090

4081-34

4902-091

4081-341

↔ L1 527 × L2 407 × L3 40 mm



16 19-21-22-23-24-26-27-29-30
32-35-36-38-41-46-50 mm

3 100-200-400 mm

460 mm

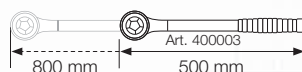

4902-090 / Art. 4081-34

Art. **4081-34**
100-500 Nm (± 2%) / 73.8-369 Lb.ft
kg-m / kg-cm / lb-in / ft-lbs

4902-091 / Art. 4081-341

Art. **4081-341**
200-1000 Nm (± 2%) / 147.6-738 Lb.ft
kg-m / kg-cm / lb-in / ft-lbs

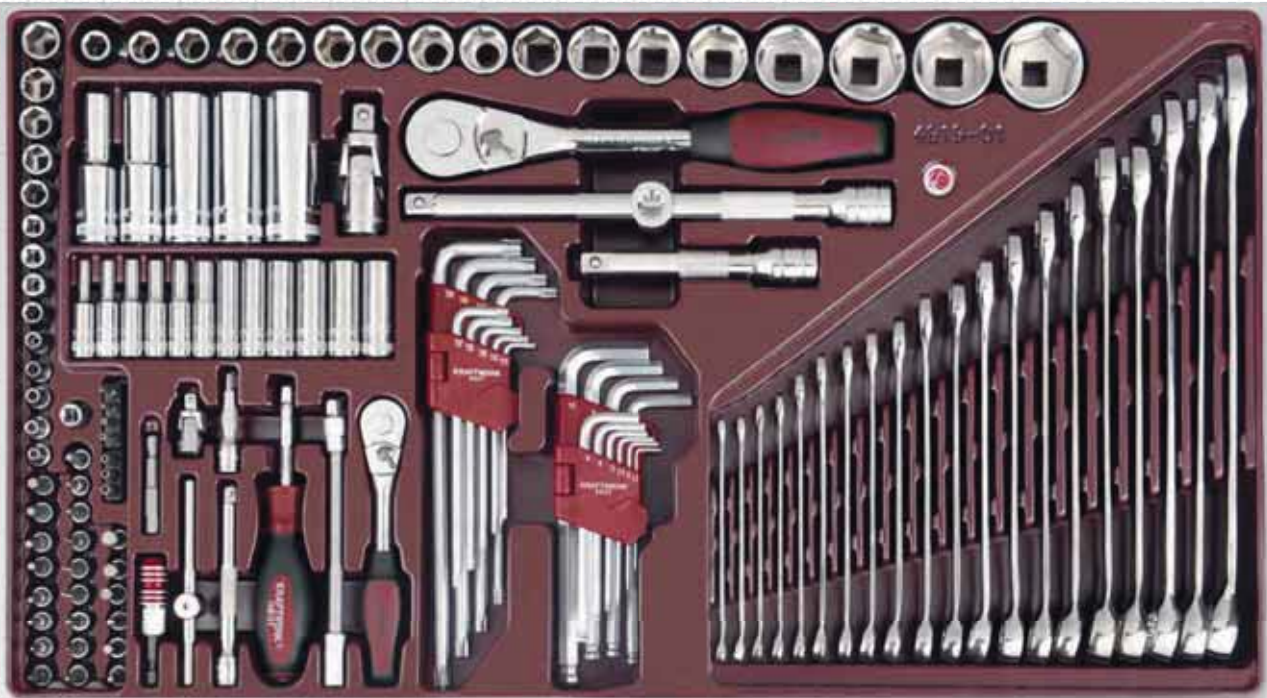

132
PCS

- 14 3.5-4-4.5-5-5.5-6-7-8-9-10-11-12-13-14 mm
- 12 4-4.5-5-5.5-6-7-8-9-10-11-12-13 mm
- 3 4-5.5-6.5 mm
- 3 PH 1-2-3
- 3 PZ 1-2-3
- 8 T8-T10-T15-T20-T25-T27-T30-T40
- 6 3-4-5-6-7-8 mm
- 1/4" 1/4"
- 1/4" 1/4"
- 2 50 mm / 100 mm
- 150 mm
- 115 mm
- 1/4" 1/4"
- 7 T10-T15-T20-T25-T27-T30-T40
- 1/4" 1/4"
- 1/4" 1/4"

- 17 10-11-12-13-14-15-16-17-18
19-21-22-24-27-30-32-34 mm
- 5 10-13-17-19-22 mm
- 1/2" 1/2"
- 2 125 mm / 250 mm
- 3/8" 1/2"
- Art. 3220
- Art. 3602
1.5-2-2.5-3-4-5-6-7-8-10 mm
- Art. 3607
T10-T15-T20-T25-T27
T30-T40-T45-T50

ergokraft

- DIN 3113**
- Art. 3505 5.5 mm
 - Art. 3506 6 mm
 - Art. 3507 7 mm
 - Art. 3508 8 mm
 - Art. 3509 9 mm
 - Art. 3510 10 mm
 - Art. 3511 11 mm
 - Art. 3512 12 mm
 - Art. 3513 13 mm
 - Art. 3514 14 mm
 - Art. 3515 15 mm
 - Art. 3516 16 mm
 - Art. 3517 17 mm
 - Art. 3518 18 mm
 - Art. 3519 19 mm
 - Art. 3520 20 mm
 - Art. 3521 21 mm
 - Art. 3522 22 mm
 - Art. 3523 23 mm
 - Art. 3524 24 mm

160
PCS

NEW
NUEVO
NOVO

Service workshop trolley
with tools
Carro taller
con herramientas
Carro multiuso
com ferramentas

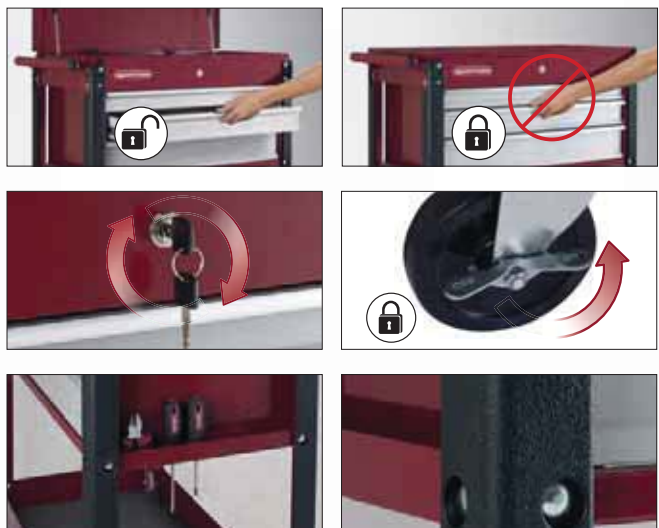

Art.			
3917-4919	3917	3	1.006



28
PCS

ergokraft



Art. 3281-180

DIN ISO 5746
180 mm



Art. 3285-200

DIN ISO 5745
200 mm



Art. 3282-160

DIN ISO 5749
160 mm



Art. 3289-160

DIN ISO 5232
160 mm



Art. 3290-250

DIN ISO 8976
250 mm

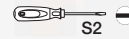

S2

Art. 4110-1 0.6 × 3 mm
Art. 4110-2 0.8 × 4 mm
Art. 4110-3 1.0 × 5 mm
Art. 4110-4 1.1 × 6 mm
Art. 4110-5 1.2 × 8 mm



S2

Art. 4112-2 1.1 × 6 mm



S2

Art. 4115-1 PH1
Art. 4115-2 PH2



S2

Art. 4117-2 PH2



Art. 2138 100-250 V



Art. 2139 12 V



DIN 6450 Form C

Art. 1350-2 2 mm
Art. 1350-3 3 mm
Art. 1350-4 4 mm
Art. 1350-5 5 mm
Art. 1350-6 6 mm
Art. 1350-8 8 mm



DIN 7250

Art. 1358-2 No. 2



DIN 6451/53

Art. 3380-18 18 mm
Art. 3380-22 22 mm



HICKORY

DIN 1041

Art. 2305 500 g



HICKORY

Art. 2336 Ø 35 mm



Art. 4700-0316 3 m × 16 m



266
PGS

NEW
NUEVO
NOVO

Tool cabinet

equipped, with standard EVA-foam inserts

Carro taller

con herramientas y bandejas de espuma EVA standard

Carro de ferramentas

com ferramentas colocadas em gavetas inseridas em espuma EVA standard

Art.			
1907-4921EVA	1907	7	1.008

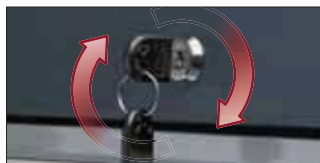

152
PGS

- 14 3.5-4-4.5-5-5.5-6-7-8-9-10-11-12-13-14 mm
- 12 4-4.5-5-5.5-6-7-8-9-10-11-12-13 mm
- 3 4-5.5-6.5 mm
- 3 PH 1-2-3
- 3 PZ 1-2-3
- 8 T8-T10-T15-T20-T25-T27-T30-T40
- 6 3-4-5-6-7-8 mm
- 1/4" 1/4"
- 1/4" 1/4"
- 2 50 mm / 100 mm
- 150 mm
- 105 mm
- 1/4" 1/4"
- 1/4" 1/4"

72 Art. 3799

60 Art. 4000B



- 17 10-11-12-13-14-15-16-17-18
19-21-22-24-27-30-32-34 mm
- 9 10-13-14-15-16-17-18-19-22 mm
- 1/2" 1/2"
- 2 125 mm / 250 mm
- 3/8" 1/2"
- 1/2" 5/16"
- 60 Art. 4020B



1/4" 25 mm
S2

- 6 4-4.5-5.5-6-6.5-8 mm
- 4 PH 1-2-3-4
- 4 PZ 1-2-3-4
- 8 T8-T10-T15-T20
T25-T27-T30-T40
- 8 T8-T10-T15-T20
T25-T27-T30-T40
- 6 3-4-5-6-7-8 mm
- 6 2-2.5-3-4-5-6 mm
- 6 5/64"-3/32"-7/64"-1/8"-9/64"-5/32"
- 3 Nos. 6-8-10
- 4 Nos. 1-2-3-4
- 4 Nos. 4-6-8-10

GLOBALBIT-Box
Art. 3777

61
PGS

101 x 90 x 32 mm



1/4" 1/4" 1/4" 1/4"

ergokraft



44
PCS

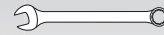

DIN 3113

Art. 3505	5.5 mm	Art. 3511	11 mm	Art. 3517	17 mm	Art. 3524	24 mm
Art. 3506	6 mm	Art. 3512	12 mm	Art. 3518	18 mm	Art. 3527	27 mm
Art. 3507	7 mm	Art. 3513	13 mm	Art. 3519	19 mm	Art. 3530	30 mm
Art. 3508	8 mm	Art. 3514	14 mm	Art. 3520	20 mm	Art. 3531	31 mm
Art. 3509	9 mm	Art. 3515	15 mm	Art. 3521	21 mm	Art. 3532	32 mm
Art. 3510	10 mm	Art. 3516	16 mm	Art. 3522	22 mm		



DIN 2936 S2



Art. 3602
1.5-2-2.5-3-4-5-6-7-8-10 mm



ergokraft

DIN 3117 / ISO 6787

Art. 3572	150 mm / 6"
Art. 3573	200 mm / 8"



S2



Art. 3608
T10-T15-T20-T25-T27
T30-T40-T45-T50

ergokraft



18
PCS



DIN ISO 5746

Art. 3281-180 180 mm



DIN ISO 5749

Art. 3282-130 130 mm
Art. 3282-160 160 mm



DIN ISO 5745

Art. 3285-200 200 mm



DIN ISO 5745

Art. 3286-200 200 mm/45°



DIN ISO 5232

Art. 3289-160 160 mm



S2

Art. 4110-1	0.6 x 3 mm
Art. 4110-2	0.8 x 4 mm
Art. 4110-3	1.0 x 5 mm
Art. 4110-4	1.1 x 6 mm
Art. 4110-5	1.2 x 8 mm
Art. 4110-6	1.6 x 10 mm



S2

Art. 4112-2	1.1 x 6 mm
-------------	------------



S2

Art. 4115-1	PH1
Art. 4115-2	PH2



S2

Art. 4117-2	PH2
-------------	-----



Art. 4128	1/4"
-----------	------



Art. 2138	100-250 V
-----------	-----------

ergokraft



22
PCS



DIN 6450 Form C

Art. 1350-2	2 mm
Art. 1350-3	3 mm
Art. 1350-4	4 mm
Art. 1350-5	5 mm
Art. 1350-6	6 mm
Art. 1350-8	8 mm



DIN 6458

Art. 1355-2	2 mm
Art. 1355-3	3 mm
Art. 1355-4	4 mm
Art. 1355-5	5 mm
Art. 1355-6	6 mm



DIN 7250

Art. 1358-1	No. 1
Art. 1358-2	No. 2

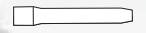

DIN 6451/53

Art. 3380-18	18 mm
Art. 3380-22	22 mm



HICKORY

DIN 1041

Art. 2303	300 g
-----------	-------

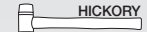

HICKORY

Art. 2336	Ø 35 mm
-----------	---------



DIN 7261

Art. 4320-1	320 mm
-------------	--------



DIN 7261

Art. 4320-2	320 mm
-------------	--------



DIN 7261

Art. 4320-3	320 mm
-------------	--------



DIN 7261

Art. 4320-4	320 mm
-------------	--------



DIN 7261

Art. 4320-5	320 mm
-------------	--------

ergokraft

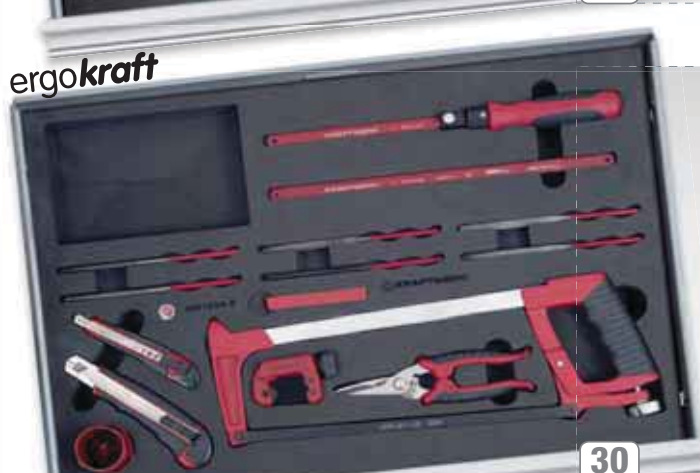

30
PCS



Art. 4321

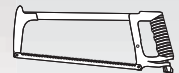

Art. 3305
300 mm

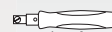

ergokraft

Art. 3308-1



HSS-Bimetall

Art. 3316-24
300 mm



ergokraft

Art. 2240



Art. 3310
9 mm



12x

Art. 3313
9 mm



Art. 3312
18 mm



5x

Art. 3314
18 mm



Art. 5433
3-30 mm CU



Art. 5470
Ø 4-40 cm



200
PGS

- 13 4-4.5-5-5.5-6-7-8-9-10-11-12-13-14 mm
- 6 6-8-10-11-12-13 mm
- 100 mm
- 1/4" 1/4"
- 1/4" 1/4"
- 1/4" 1/4"
- (45) Art. 1000

- 1/4" 1/4" 1/4"
- 1/4" 1/4"

- 16 10-11-12-13-14-15-16-17-18
19-21-22-24-27-30-32 mm
- 2 16 mm / 21 mm
- 1/2" 1/2"
- 2 125 mm / 250 mm
- 3/8" 1/2"
- 1/2" 5/16"
- (45) Art. 1020
- Art. 1110-1 3.2 x 75 mm
Art. 1110-2 4.0 x 100 mm
Art. 1110-3 5.0 x 100 mm
Art. 1110-4 6.0 x 150 mm
Art. 1110-5 8.0 x 150 mm
- Art. 1112-2 6.0 x 38 mm
- Art. 1115-1 PH1
Art. 1115-2 PH2
- Art. 1117-2 PH2
- Art. 2138 110-250 V

- 4 2-2.5-3-4 mm
- 3 PH00-2xPH0 Art. 3180
- 2 PZ00-PZ0
- 6 T6-T7-T8-T9-T10-T15
- 3 1.5-2-2.5 mm
- 3 1.5-2-2.5 mm
- 4 mm

286
PGS

NEW
NUEVO
NOVO

Tool-cabinet

practically equipped with 287 quality tools.

Carro taller

equipado con 287 prácticas herramientas de calidad.

Carro de ferramentas

equipado com 287 ferramentas de qualidade.



100 % COMPLETO Compatible

Art.			
1097	2907	7	1.007





S2
quality

42
PCS

20 5.5-6-7-8-9-10-11-12-13-14-15
16-17-18-19-20-21-22-23-24 mm

1.5-2-2.5-3-4-5-6-8-10 mm
 T10-T15-T20-T25-T27-T30-T40-T45-T50

Art. 1281-180 180 mm
DIN ISO 5746

Art. 1282-160 160 mm
DIN ISO 5749

Art. 1285-200 200 mm
DIN ISO 5745

Art. 1289-160 160 mm
DIN ISO 5232



CrV

44
PCS

Art. 1350-2 2 mm
DIN 6450 Form C Art. 1350-3 3 mm
Art. 1350-4 4 mm
Art. 1350-5 5 mm
Art. 1350-6 6 mm
Art. 1350-8 8 mm

Art. 1358-2 No. 2
DIN 7250

Art. 3380-18 18 mm
DIN 6451/53 Art. 3380-22 22 mm

HICKORY Art. 2303
DIN 1041 300 g

HICKORY Art. 2336
Ø 35 mm

Art. 4320-1 320 mm
DIN 7261

Art. 4320-2 320 mm
DIN 7261

Art. 4320-3 320 mm
DIN 7261

Art. 4320-4 320 mm
DIN 7261

Art. 4320-5 320 mm
DIN 7261

Art. 4321

Art. 3305
300 mm

Art. 3308-1
ergokraft

HSS-Bimetall Art. 3316-24
300 mm

Art. 3310
9 mm

12x Art. 3313
9 mm

Art. 3312
18 mm

5x Art. 3314
18 mm

ergokraft Art. 2240



186
PCS

14 3.5-4-4.5-5-5.5-6-7-8-9-10-11-12-13-14 mm	16 10-11-12-13-14-15-16-17-18-19-21-22-24-27-30-32 mm
6 6-8-10-11-12-13 mm	2 16 mm / 21 mm
2 50 mm / 100 mm	2 125 mm / 250 mm
1/4" 1/4"	3/8" 1/2"
1/4" 1/4"	1/2" 5/16"
45 Art. 1000	45 Art. 1020
1/4" 1/4" 1/4"	1.5-2-2.5-3-4-5-6-8-10 mm
1/4" 1/4"	T10-T15-T20-T25-T27-T30-T40-T45-T50

337
PGS

Tool cabinet
with tools

Carro
con herramientas

Carro
com ferramentas

NEW
NUEVO
NOVO



Art.			
1096	1906	6	1.008

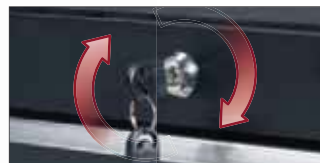



56
PCS

14 6-8-9-10-11-12-13-14
15-16-17-18-19-22 mm

HICKORY
DIN 1041 Art. 2303 300 g

HICKORY Art. 2336 Ø 35 mm

Art. 4320-1

Art. 4321

Art. 4996

S2 Art. 1110-1 3.2 x 75 mm
Art. 1110-2 4.0 x 100 mm
Art. 1110-3 5.0 x 100 mm
Art. 1110-4 6.0 x 150 mm
Art. 1110-5 8.0 x 150 mm

S2 Art. 1112-2 6.0 x 38 mm

S2 Art. 1115-1 PH1
Art. 1115-2 PH2

S2 Art. 1117-2 PH2

GS Art. 2138 100-250 V

4mm
25 mm

4 2-2.5-3-4 mm Art. 3180

3 PH00-2xPH0

2 PZ00-PZ0

6 T6-T7-T8-T9-T10-T15

3 1.5-2-2.5 mm

3 1.5-2-2.5 mm

4 mm



95
PCS

Art. 1281-180 180 mm
DIN ISO 5746

Art. 1282-160 160 mm
DIN ISO 5749

Art. 1285-200 200 mm
DIN ISO 5745

Art. 2221-250 250 mm

Art. 2225 240 mm

Art. 1350-2 2 mm
DIN 6450 Form C Art. 1350-3 3 mm
Art. 1350-4 4 mm
Art. 1350-5 5 mm
Art. 1350-6 6 mm
Art. 1350-8 8 mm

Art. 1358-2 2 mm
DIN 6458

Art. 3380-18 18 mm
DIN 6451/53 Art. 3380-22 22 mm

Art. 3305 300 mm

Art. 3310 9 mm

12x Art. 3313 9 mm

Art. 3312 18 mm

15x Art. 3314 18 mm

Art. 2240
ergokraft

50



Workbenches

with drawer cabinets with ball bearing guided, full extension drawers and central lock. Load capacity per drawer up to 20 kg, total load capacity 300 kg, delivered with a multiplex plate of 3 cm height, water resistant and durable against dirt, oil and grease to a large extent.



Bancos de trabajo

con armario de herramientas con cajones completamente extraíbles, con sistema de rodamientos, bloqueo individual y cerradura central. Capacidad de carga por cajón de 20 kg, capacidad de carga total de 300 kg, equipados con una plancha multiplex de 3 cm de espesor, resistente al agua y repelente a la suciedad, aceites y grasas en general.

Bancada de trabalho

com armário de ferramentas com gavetas extensíveis com guias de rolamentos e trancas individuais e fecho centralizado. Capacidade de carga por gaveta de 20 kg. Capacidade de carga total de 300 kg. Equipado com um tampo Multiplex de 3 cm espessura, resistente a água, a sujidade, óleos e graxa em geral.



Workbench

with leg and 1 drawer cabinet

Banco de trabajo

con soporte y armario de herramientas

Bancada de trabalho

com suporte e armário de ferramentas

Workbench

2 drawer cabinets

Banco de trabajo

con 2 armarios de herramientas

Bancada de trabalho

com 2 armários de ferramentas

Art.	
7534	6

Art.	
7504	6 + 1

	L1 / mm	L2 / mm	L3 / mm
	1600	600	900
A	500	500	100

	L1 / mm	L2 / mm	L3 / mm
	2200	800	900
A	500	500	100
B	500	500	500

COMPLETO Serie 4901





Tool assortment
Surtido herramientas
Sortido de ferramentas

Art.	
4921	4901-01B, 4901-03B, 4901-04B, 4901-06B, 4901-07B, 4901-10B, 4901-11B, 4901-13B, 4901-14B

↔ L1 502 × L2 167 × L3 45 mm

Workbenches
with integrated tool assortment
Bancos de trabajo
con surtido herramientas integrado
Bancada de trabalho
com sortido de ferramentas integrado

Art.			
7534-4921	7534	6	1.068
7504-4921	7504	6 + 1	1.068



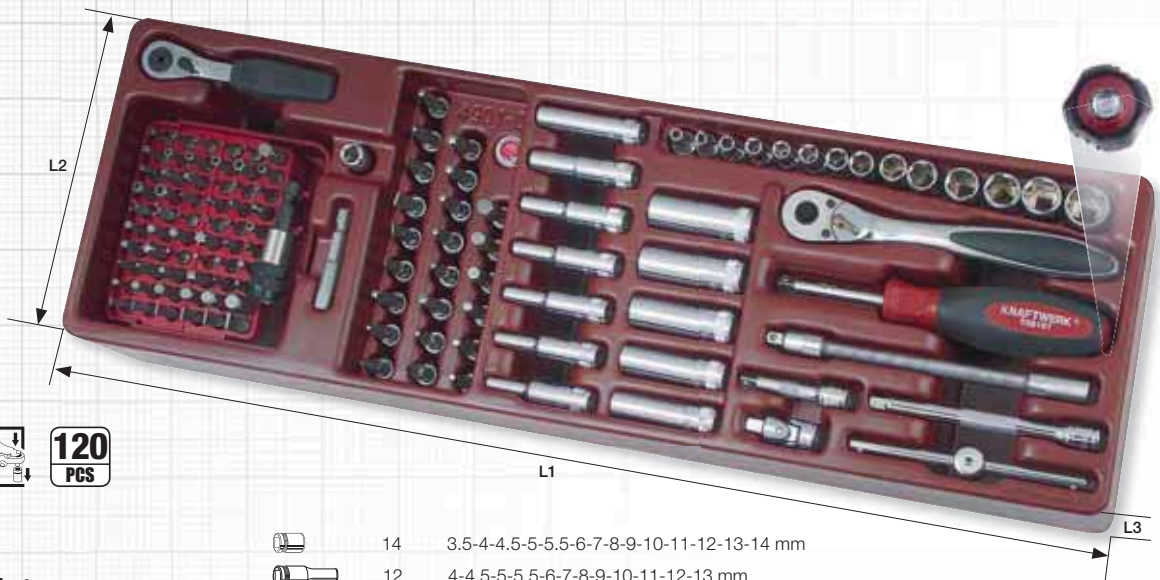

Socket wrench tray
Bandeja llaves vaso
Conjunto de chaves de caixa

Art.
4901-01B

↔ L1 502 × L2 167 × L3 45 mm

- 14 3.5-4-4.5-5-5.5-6-7-8-9-10-11-12-13-14 mm
- 12 4-4.5-5-5.5-6-7-8-9-10-11-12-13 mm
- 3 4-5.5-6.5 mm
- 3 PH 1-2-3
- 3 PZ 1-2-3
- 8 T8-T10-T15-T20-T25-T27-T30-T40
- 6 3-4-5-6-7-8 mm

- 2 50 mm / 100 mm
- 150 mm
- 105 mm
- 1/4" 1/4"
- 1/4" 1/4"

- 72 Art. 3799
- 60 Art. 4000B

- 6 4-4.5-5.5-6-6.5-8 mm
- 4 PH 1-2-3-4
- 4 PZ 1-2-3-4
- 8 T8-T10-T15-T20-T25-T27-T30-T40
- 8 T8-T10-T15-T20-T25-T27-T30-T40
- 6 3-4-5-6-7-8 mm
- 6 2-2.5-3-4-5-6 mm
- 6 5/64"-3/32"-7/64" 1/8"-9/64"-5/32"
- 3 Nos. 6-8-10
- 4 Nos. 1-2-3-4
- 4 Nos. 4-6-8-10
- 1/4" 1/4"
- 1/4" 1/4"



Socket wrench tray
Bandeja llaves vaso
Conjunto de chaves de caixa

Art.
4901-03B

↔ L1 502 × L2 167 × L3 45 mm

- 17 10-11-12-13-14-15-16-17-18 19-21-22-24-27-30-32-34 mm
- 9 10-11-12-13-14-15-17-19-22 mm
- 1/2" 1/2"
- 2 125 mm / 250 mm
- 3/8" 1/2"
- 1/2" 5/16"
- 60 Art. 4020B



34
PCS

Combination wrench and ballpoint hex/TX key tray
Bandeja llaves combinadas/macho hexagonales bola/TX
 Conjunto de chaves de boca-luneta/sextavadas interior

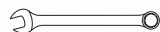

DIN 3113

Art. 3505	5.5 mm	Art. 3513	13 mm
Art. 3506	6 mm	Art. 3514	14 mm
Art. 3507	7 mm	Art. 3515	15 mm
Art. 3508	8 mm	Art. 3516	16 mm
Art. 3509	9 mm	Art. 3517	17 mm
Art. 3510	10 mm	Art. 3518	18 mm
Art. 3511	11 mm	Art. 3519	19 mm
Art. 3512	12 mm		



DIN 2936 S2



● ● Art. 3602

1.5-2-2.5-3-4-5-6-7-8-10 mm



XXL S2

★ ★ Art. 3607

T10-T15-T20-T25-T27
T30-T40-T45-T50

Art.

4901-13B

↕ L1 502 × L2 167 × L3 45 mm



ergokraft

10
PCS

Combination wrench tray
Bandeja llaves combinadas
 Conjunto de chaves de boca-luneta

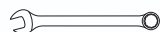

DIN 3113

Art. 3520	20 mm	Art. 3524	24 mm
Art. 3521	21 mm	Art. 3527	27 mm
Art. 3522	22 mm	Art. 3530	30 mm
Art. 3523	23 mm	Art. 3532	32 mm



ergokraft

DIN 3117 / ISO 6787

Art. 3572 150 mm / 6"
Art. 3573 200 mm / 8"

Art.

4901-14B

↕ L1 502 × L2 167 × L3 45 mm

ergokraft



S2
quality







12
PCS

Screwdriver tray
Bandeja destornilladores
Conjunto de chaves de parafusos

Art.

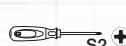
4901-04B

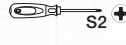
↔ L1 502 × L2 167 × L3 45 mm

	Art. 4110-1	0.6 × 3 mm
	Art. 4110-2	0.8 × 4 mm
	Art. 4110-3	1.0 × 5 mm
	Art. 4110-4	1.1 × 6 mm
	Art. 4110-5	1.2 × 8 mm
	Art. 4110-6	1.6 × 10 mm
	Art. 4115-1	PH1
	Art. 4115-2	PH2

	Art. 4112-2	1.1 × 6 mm
	Art. 4117-2	PH2
	Art. 4128	1/4"
	Art. 2138	100-250 V



ergokraft

6
PCS

Pliers tray
Bandeja alicates
Conjunto de alicates

Art.

4901-07B

↔ L1 502 × L2 167 × L3 45 mm

 **DIN ISO 5746**
Art. 3281-180 180 mm

 **DIN ISO 5749**
Art. 3282-140 140 mm
Art. 3282-160 160 mm

 **DIN ISO 5745**
Art. 3285-200 200 mm

 **DIN ISO 5745**
Art. 3286-200 200 mm/45°

 **DIN ISO 5232**
Art. 3289-160 160 mm







12
PCS

File tray
Bandeja limas
Conjunto de limas

Art.
4901-10B

↔ L1 502 × L2 167 × L3 45 mm

-  Art. 4320-1 320 mm
DIN 7261
-  Art. 4320-2 320 mm
DIN 7261
-  Art. 4320-3 320 mm
DIN 7261
-  Art. 4320-4 320 mm
DIN 7261
-  Art. 4320-5 320 mm
DIN 7261

▣▣▣▣▣ Art. 4321

 Art. 5470 Ø 4-40 cm









23
PCS

Cutting tool tray
Bandeja herramientas corte
Conjunto de herramientas de corte

Art.
4901-11B

↔ L1 502 × L2 167 × L3 45 mm

-  **ergokraft** Art. 3310 9 mm
-  12x Art. 3313 9 mm
-  **ergokraft** Art. 3312 18 mm
-  5x Art. 3314 18 mm
-  Art. 3305 300 mm

-  **ergokraft** Art. 3308-1
-  HSS-Bimetall Art. 3316-24 300 mm

 Art. 2240
ergokraft

 Art. 5433 3-30 mm CU



17
PCS

Striking tool tray
Bandeja herramientas golpe
Conjunto de martelos e
punções

Art.

4901-06B

↔ L1 502 × L2 167 × L3 45 mm



Art. 1350-2	2 mm
Art. 1350-3	3 mm
Art. 1350-4	4 mm
Art. 1350-5	5 mm
Art. 1350-6	6 mm
Art. 1350-8	8 mm



Art. 1355-2	2 mm
Art. 1355-3	3 mm
Art. 1355-4	4 mm
Art. 1355-5	5 mm
Art. 1355-6	6 mm



Art. 1358-1	No. 1
Art. 1358-2	No. 2

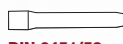

Art. 3380-18	18 mm
Art. 3380-22	22 mm



Art. 2303	300 g
-----------	-------

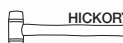

Art. 2336	Ø 35 mm
-----------	---------



Multi-purpose shelf trolley

- 3 big shelves, made of polypropylene and fiberglass
- Very solid construction for universal use, aluminium rods
- 4 swivel castors Ø 100 mm, 2 of them braked
- Shelf capacity: 80 kg
- Trolley capacity: 160 kg

Mesa de trabajo móvil

- 3 grandes baldas en polipropileno y fibra de vidrio
- Construcción muy sólida para uso universal, barras en aluminio
- ruedas giratorias Ø 100 mm, 2 con freno
- Capacidad por bandeja: 80 kg
- Capacidad total: 160 kg

Carro multiuso de prateleiras

- 3 prateleiras grandes in polipropileno e fibra de vidro
- Construção sólida para usos universais, hastes de alumínio
- 4 rodízios giratórios Ø 100 mm, 2 deles com travão
- Capacidade da prateleira: 80 kg
- Capacidade do carro: 160 kg

Art.	
3912	0

	L1 / mm	L2 / mm	L3 / mm
	910	480	1040
A	660	390	300



COMPLETO Compatible

Multi-purpose three shelf trolley

with ball bearing guided drawer

Mesa de trabajo móvil

con cajón con sistema de rodamientos

Carro multiusos de prateleiras

com gaveta de rolamento de esferas

Art.	
3913	1 / Art. 3928

	L1 / mm	L2 / mm	L3 / mm
	910	480	1040
A	570	410	112
B	660	390	190
C	660	390	300



Drawer

ball bearing guided, for multi-purpose shelf trolley 3912

Cajón

con sistema de rodamientos para mesa de trabajo móvil 3912

Gaveta

com sistema de rolamentos para carro multiusos 3912

COMPLETO Compatible



Art.	
3928	1

↕ L1 570 × L2 410 × L3 112 mm



Waste bin

for multi-purpose shelf trolley 3912/3913
made of oil and acid resistant polypropylene

Cubo de basura

para mesa de trabajo móvil 3912/3913
en polipropileno, resistente al aceite e a los ácidos

Caixote do lixo

para carro multiuso de prateleiras 3912/3913
in polipropileno, resistentes ao óleo e ao ácido

NEW
NUEVO
NOVO



Art.		
3912-99	3912/3913	1.075

↕ L1 360 × L2 250 × L3 430 mm

19L



Hand truck

foldable

Carrito

plegable

Carro de cargas

desmontável

Art.

3914

L1 / mm	L2 / mm	L3 / mm	L4 / mm
430	255	max. 995	min. 740

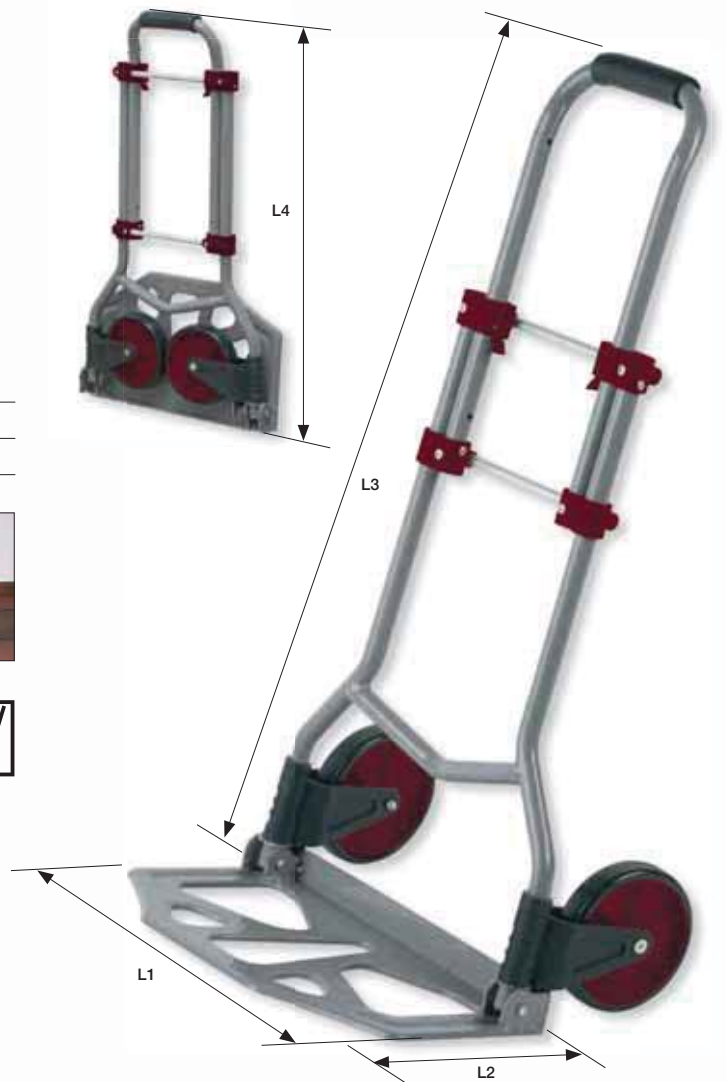

Working platform ALU

Plataforma de trabajo en aluminio

Plataforma de trabalho em alumínio

Art.

3985



Telescopic ladder
Escalera telescópica en aluminio
Escada telescópica em alumínio

Alu

Art.	kg
3986	11

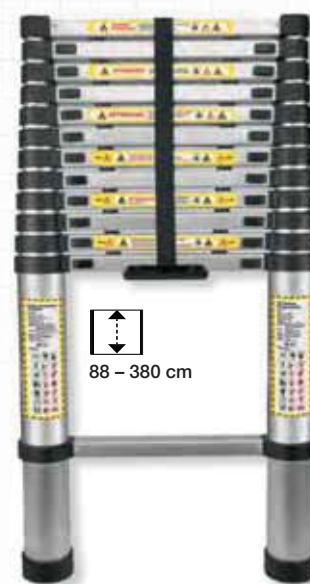
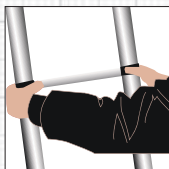

Aluminium telescopic safety ladder
Escalera de aluminio telescópica combinada
Escada de alumínio telescópica combinado

Alu EN131

Art.	kg
3987	13.8

