

UT251A/B/C Precision Clamp-on Leakage Current Meter User Manual

Warning !

Thank you for purchasing the UT251 series precision clamp-on leakage current meter and for the full use of the product, please:

- Read the user manual carefully.
- Strictly observe the safety rules and notes listed in the manual.
- ◆ In any case, please pay attention to the safety in using the meter. Note labeled words and symbols on the panel and backboard of the meter.
- ◆ Avoid placing and storing meter for a long time in the environment with high temperature, moisture, condensation and with straight sunshine.
- ◆ Avoid strong shock on the clamp head and deformation of iron core or fluctuation of magnetic inductivity, which will affect meter precision.
- ◆ Please replace battery in time if there is low voltage of it.
- ◆ Take out battery when do not intend to use the meter for a long time.
- ◆ Note the battery polarity in replacing the battery.
- ◆ Operation, dismantle and maintenance of the meter shall be conducted by the personnel with authorized qualification.
- ◆ Please stop using the meter and store it and deliver it for treatment to the authorized and qualified institution if continuing usage of it might bring about danger.
- ◆ Note the safety symbol “” in the manual and on the meter, the user shall conduct operations in accordance with instructions.
- ◆ Note the symbol “” indicating extremely dangerous, in the manual, the user shall conduct operations strictly in accordance with instructions.

I. Overview

UT251 series precision clamp-on leakage current meter intended for measuring AC leakage current, current are designed by adopting state-of-the-art CT and digital integration technologies and with small size, high precision and perfect function. It is widely applicable in such fields as electricity, communication, meteorology, railway, oilfield, structure, measurement, scientific research and teaching units and mineral

enterprises etc. The induction iron core, a special alloy, adopts magnetic shielding technology to avoid the impact from outside magnetic field, assuring the high precision, stability and reliability for year-round measurement.

Software of the meter with RS232 ports allows the online real time monitoring and history check, dynamic display, maximum, minimum and average value indication. The meter has functions such as alarm value setting, alarm indicating, and reading, storing and printing of the history data etc. More than that, it can hold peak value and data and store data, convenient to operate and it is the necessity for safety test for electrician.

II. Difference between Types

Types	Range	Resolution	Dimension of Clamp Jaw
UT251A	0.000mA~60.00A	1uA	25mm×30mm
UT251B	0.00mA~300.0A	10uA	35mm×40mm
UT251C	0.0mA~600A	0.1mA	35mm×40mm

III. Electrical Symbol

	Extremely dangerous! Operator must strictly observe safety rules or face electric shocking, resulting in personal harm or injury and death accidents.
	Danger! Operator must strictly observe safety rules or face electric shocking, resulting in personal harm or injury and death accidents.
	Warning! Please strictly observe safety rules or result in personal injury or damage to equipment.
	Double insulation
	Alternative current (AC)
	Directive current (DC)

IV. Technical Specification

Function	AC leakage current measurement, AC current measurement, online AC current measurement
Power source	Zn-Mn dry battery 6F22 9V
Test methods	Clamp CT, integration method
Display mode	4 digit LCD display
Dimension of meter	High/width/thickness: roughly 175mm×70mm×38mm

LCD dimension	35mm×21.5mm; Display area: 32mm×15mm
Acquisition rate	About 2 times per second
Frequency	50Hz、60Hz Automatic recognition
Shift	Full automatic shift
Measurement accuracy (23℃ ±3℃, 70% RH below)	0~60A: ±1.5%±5dgt 60A~200A: ±2%±5dgt 200A~300A: ±3%±5dgt 300A~600A: ±4%±5dgt
Line voltage	Line test of AC600V below
Data storage	99 groups, flickering display of “FULL” means full memory.
RS232 ports	With RS2323 ports, storage data could be uploaded to computer and realize software monitoring,
Communication wire	RS232 communication wire with length of 1.8m
Peak value hold	Hold the peak value capture, just to press key in the test for a long time to display peak value.
Data hold	Data hold function: symbol “DH” display.
Overflow display	Overflow of range function: symbol “OL” display.
Automatic power-off	5 minutes after power-on, the meter shall power off automatically to reduce battery consumption.
Battery voltage	When battery voltage reduces to about 7.2V, the battery low voltage symbol shall display to remind replacing battery.
Mass of meter	About 120g (inclusive of battery)
Rating power	About 8m
Working temperature & humidity	-10℃~40℃; below 80%rh
Storage temperature & humidity	-10℃~60℃; below 70%rh
Insulation intensity	AC2kV/rms (between iron core and case)
Applicable safety rules	IEC1010-1, IEC1010-2-032, Pollution Grade 2, CAT III (600V)

V. Meter Structure

1. Clamp head
2. Meter upper cover
3. Trigger (control opening and closing)
4. key (combination key)

5. key (combination key)
6. LCD display
7. RS232 ports, digital could be uploaded to computer
8. Meter lower cover
9. Batter cover

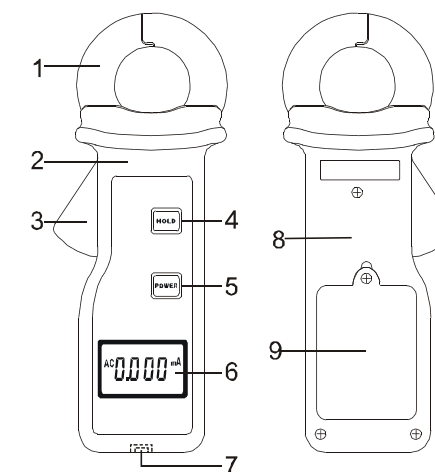

VI. Operation Method

1. Power On/Power Off

Press key to power on, LCD display and press the key again to power off. LCD will flicker about 5 minutes after power on of meter, indicating to power off automatically, and 30 seconds after flickering, it will shut off to reduce battery consumption. If press key when LCD is flickering, the meter will continue working 5 minutes. If LCD display is dull after power on, please replace battery because of the low battery voltage.

2. Measurement of Leakage Current and Current

Electricity, extremely dangerous!

Operation shall be conducted by personnel being trained and with authorized qualification. Operator must strictly observe safety rules or face electric shocking, resulting in personal harm or injury and death accidents.

Dangerous!

Forbid to measure current exceeding the upper limits or face electric shocking, personal injury or damage to equipment.

- 1) Turn on the power of meter.
- 2) Press down trigger to open clamp head to clamp on the wire under measurement.(Notes: fully close the clamp head)

Notes:

- Clamp on live wire and neutral wire, i.e. to measure leakage current of the electric equipment.(note the 2 wires)
- Clamp on ground wire, i.e. to measure ground wire leakage current of the electric equipment. (note the single wires)
- Clamp on main line, i.e. to measure total current of the main lines (note the single wires)

Figure for reference

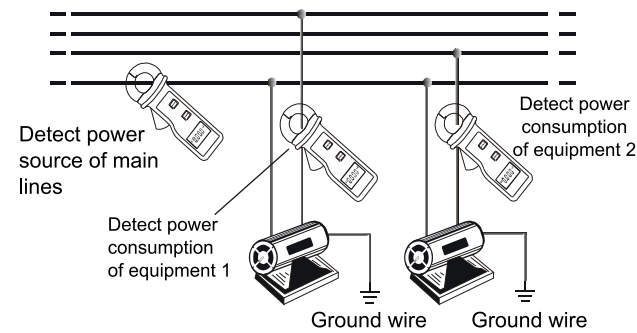
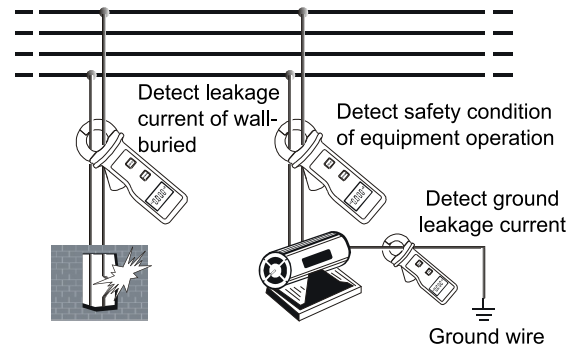

Notes:

- For safety, please move meter away from the wire being measured after confirming completion of correct operation and measurement.
- 3) Read LCD display data. Displaying of the symbol “OL A” means that the current of wire under measurement exceeds the maximum upper limits of meter and please select higher range meter for test.

Location that not easy to read, please use data hold function. If the symbol [DH] appears, please release the data hold status and continue to test.

3. Peak Value Hold

Press key **[HOLD]** more than 3 seconds in test until symbol “PEHd” appears. The meter shall automatically capture and display current peak value during the time period of the line, loose the key to back to test status.

4. Data hold, cancellation, storage, check and deletion

- 1) Press key **[HOLD]** no more than 3 seconds in test until symbol “DH” appears, hold the present data and storage with automatic numbering. Press the key again to cancel hold and meter shall continue to measure. If storage data have reached 99 groups, presses key **[HOLD]** to display symbol “FULL” , indicating storage data is full. Press to key **[HOLD]** to cancel flickering of “FULL” and back to measurement mode.
- 2) Press key **[HOLD]+[POWER]** to enter into data check mode and display the first group of data, and press key **[HOLD]** to check storage data in cycle, if no storage data displaying “null” , press key **[POWER]** to back to data check mode.
- 3) Enter into data check mode, presses key **[HOLD]** more than 3 seconds to delete all storage data and when meter displays symbol “DEL” , indicating deletion finishes, and then back to test status automatically.

VII. Quick Check for Function

Key [POWER] press short time	Power on/power off/exit
Key [HOLD] press short time	Data hold/relieve/storage
Key [HOLD] press no more 3 seconds continuously	Peak value hold (under measurement mode)
Key [HOLD] press 3 seconds continuously	Data delete (under check mode)
[HOLD] key + [POWER] key	Data check/browse(HOLD key)

VIII. Display Examples

1. Leakage current being measured is 0.25mA.

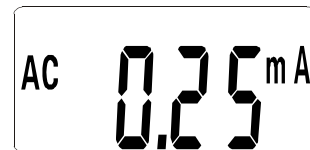

2. Low electricity of battery, please replace battery.

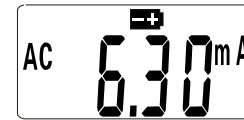

3. Leakage current being measured is 5.00mA. Measurement data hold. Automatic storage as group 03 data.



4. Check the storage data group 03.

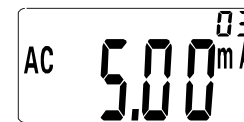

IX. Battery Replacement

Warning !

- Do not test in case of uncovered the battery or dangerous.
- Note the battery polarity or damaging the meter.
- Low electricity of battery, please replace it.
- Please take out battery when do not intend to use the meter for a long time.

- 1) When the electricity of battery is insufficient, meter will display battery low voltage symbol, and please replace the battery.
- 2) Press key **[POWER]** to power off, confirm meter is under power-off status and open the battery cover to replace new and qualified battery with noting the battery model, and then cover the battery.

X. Packing List

Clamp meter	One
Data uploading software(disk)	One
RS 232 dedicated communication wire	One
Batter (6F22 9V)	One
Packing case/user manual/warranty	One set

©Copyright 2011 Uni-Trend Group Limited. All rights reserved.

Manufacturer:
Uni-Trend Technology(China) Limited
No 6, Gong Ye Bei 1st Road
Songshan Lake National High-Tech Industrial
Development Zone, Dongguan City
Guangdong Province
China
Postal Code:523 808

Headquarters:
Uni-Trend Group Limited
Rm901, 9/F, Nanyang Plaza
57 Hung To Road
Kwun Tong
Kowloon, Hong Kong
Tel: (852) 2950 9168
Fax: (852) 2950 9303
Email: info@uni-trend.com
http://www.uni-trend.com

说明书菲林做货要求:

序号	项目	内容	
1	尺寸	外形尺寸285*210±1mm; 折叠尺寸105*95±1mm	
2	材质	60g书纸做货, 单张双面印刷	
3	颜色	黑白印刷	
4	外观要求	印刷完整清晰, 版面整洁. 无分层. 残损. 毛边等缺陷.	
5	装订方式	285mm方向S形折叠, 210mm方向中心点对折	
6	表面处理	/	
7	其它	/	
版本		REV. 1	
DWH 设计	蒙淑洁2013/5/23	MODEL UT251A/UT251B 机型: UT251C	Part NO. 物料编号: 110401103623
CHK 审核		 优利德科技(中国)有限公司 UNI-TREND TECHNOLOGY (CHINA) LIMITED	
APPRO. 批准	万国强2013/5/23		