

EN
NEW

BC



 **PEDROLLO**[®]
... the spring of life

NEW

Drainage pumps with cast iron pump body for using in domestic, civil and industrial applications.

TECHNICAL CHARACTERISTICS

- ▶ Cast iron pump body subjected to Epoxy Electrocoating Treatment. This treatment guarantees high resistance to oxidation.
- ▶ Stainless steel double-channel type impeller.
- ▶ Precision cast stainless steel handle.
- ▶ Stainless steel motor shaft.
- ▶ Double mechanical seals.
- ▶ Float switch equipped with patented tilting system (patented).
- ▶ Supply cable equipped with anti-tear system (patented).

INSTALLATION AND USE

BC submersible pumps are suitable for draining **dirty water and sewage** in domestic and civil applications. They are equipped with a DOUBLE-CHANNEL stainless steel impeller and are capable of pumping liquids containing short fibred suspended solids up to $\varnothing 50$ mm.

They are ideal for pumping sewage water, waste water, surface water and water mixed with mud in locations such as holiday homes and detached homes.

These pumps distinguish themselves for their reliability, which can be best appreciated under automatic operating conditions in fixed installations.

APPLICATION LIMITS

- **5 m** maximum immersion depth
- Maximum liquid temperature **+40 °C**
- Passage of suspended solids up to **$\varnothing 50$ mm**
- Minimum immersion depth for continuous service: up to **305 mm** for BC10/50-N, up to **320 mm** for BC15/50-N

STANDARD SUPPLY

- Complete with:
 - **5 m** long power cable for BC10/50-N
 - **10 m** long power cable for per BC15/50-N
- Float switch for single-phase versions

CHARACTERISTIC CURVES AND PERFORMANCE DATA

50 Hz n= 2900 1/min

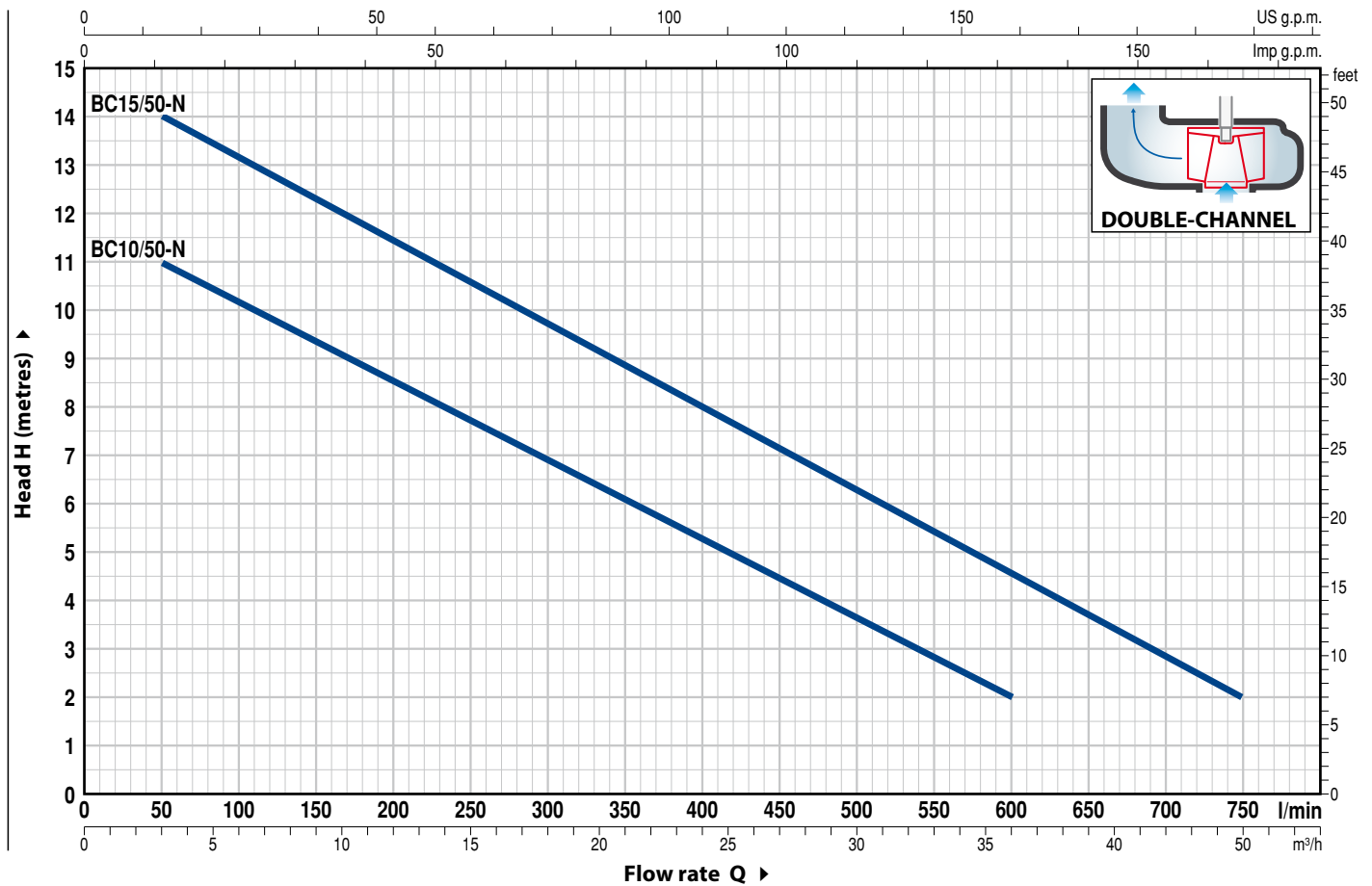

| MODEL | | POWER | | Q | Flow rate | | | | | | | | | | | | |
|--------------|-------------|-------|-----|----------|-------------------|----|-----|------|-----|-----|-----|-----|-----|-----|----|--|--|
| Single-phase | Three-phase | kW | HP | | m ³ /h | 0 | 3 | 6 | 12 | 18 | 24 | 30 | 36 | 42 | 45 | | |
| BCm 10/50-N | BC 10/50-N | 0.75 | 1 | l/min | 0 | 50 | 100 | 200 | 300 | 400 | 500 | 600 | 700 | 750 | | | |
| BCm 15/50-N | BC 15/50-N | 1.1 | 1.5 | H metres | 12 | 11 | 10 | 8.5 | 7 | 5 | 3.6 | 2 | | | | | |
| | | | | | 15 | 14 | 13 | 11.5 | 9.7 | 8 | 6.3 | 4.6 | 2.9 | 2 | | | |

Q = Flow rate H = Total manometric head

Tolerance of characteristic curves in compliance with EN ISO 9906 Grade 3.

POS. COMPONENT CONSTRUCTION CHARACTERISTICS

| | | | | | |
|--|---|-------------------------------------|------------------------|------------------------|----------------------------|
| 1 PUMP BODY | Cast iron subjected to Epoxy Electrocoating Treatment, with threaded port in compliance with ISO 228/1 | | | | |
| 2 BASE | Stainless steel AISI 304 | | | | |
| 3 IMPELLER | Stainless steel AISI 304 DOUBLE-CHANNEL type | | | | |
| 4 MOTOR CASING | Stainless steel AISI 304 | | | | |
| 5 MOTOR CASING PLATE | Stainless steel AISI 304 | | | | |
| 6 MOTOR SHAFT | Stainless steel EN 10088-3 - 1.4104 | | | | |
| 7 SHAFT WITH DOUBLE MECHANICAL SEAL SEPARATED BY AN OIL CHAMBER | | | | | |
| | <i>Seal Model</i> | <i>Shaft Diameter</i> | <i>Stationary ring</i> | <i>Rotational ring</i> | <i>Materials Elastomer</i> |
| | MG1-14D SIC | Ø 14 mm | Silicon carbide | Silicon carbide | NBR |
| 8 BEARINGS | 6203 ZZ / 6203 ZZ | | | | |
| 9 CAPACITOR | | | | | |
| | <i>Pump Single-phase</i> | <i>Capacitance (230 V or 240 V)</i> | | <i>(110 V)</i> | |
| | BCm 10/50-N | 20 µF 450 VL | 30 µF 250 VL | | |
| | BCm 15/50-N | 25 µF 450 VL | - | | |
| 10 ELECTRIC MOTOR | <ul style="list-style-type: none"> - Single-phase 230 V - 50 Hz with thermal overload protector built-in to the winding - Three-phase 400 V - 50 Hz - Insulation: F class - Protection: IP X8 | | | | |
| 11 POWER CABLE | 5 metre long "H07 RN-F" cable (10 metre for BC15/50-N) (with Schuko plug on single-phase versions only) | | | | |
| 12 FLOAT SWITCH | (only for single-phase versions) | | | | |

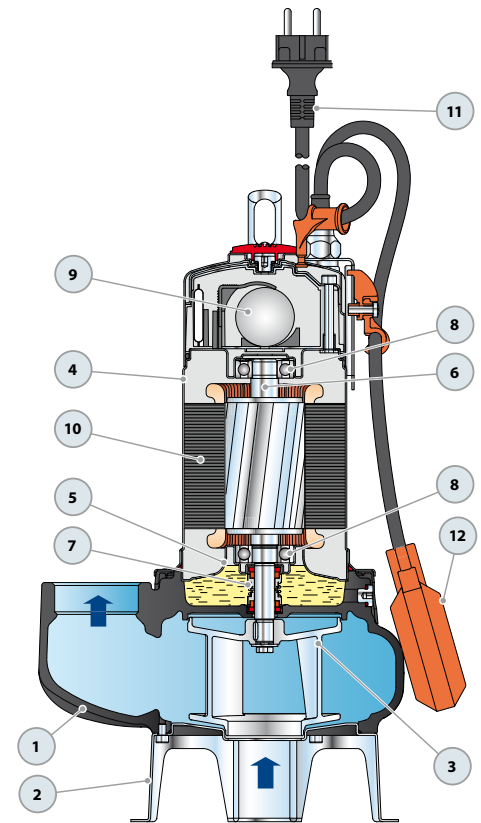

DIMENSIONS

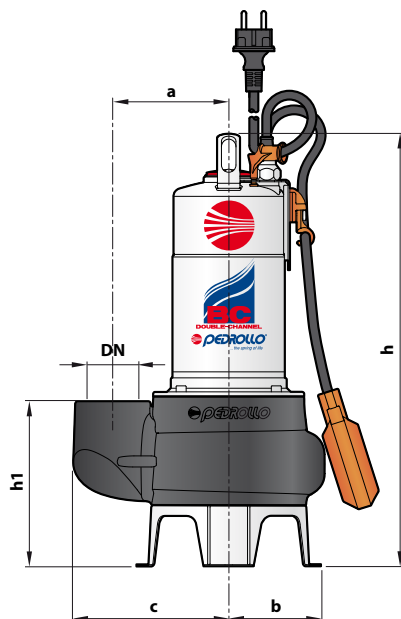

Typical installation

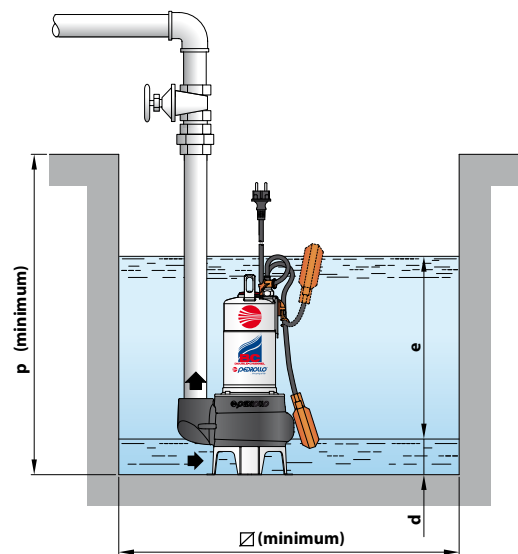

| MODEL | | PORT DN | solids passage | DIMENSIONS mm | | | | | | | | |
|--------------|-------------|---------|----------------|---------------|----|-----|-----|-----|----|----------|-----|-----|
| Single-phase | Three-phase | | | a | b | c | h | h1 | d | e | p | Ø |
| BCm 10/50-N | BC 10/50-N | 2" | Ø 50 mm | 115 | 95 | 155 | 431 | 164 | 60 | variable | 500 | 500 |
| BCm 15/50-N | BC 15/50-N | | | | | | 446 | | | | | |



Pedrollo S.p.A. – Via Enrico Fermi, 7 – 37047 – San Bonifacio (VR)
tel. +39 045 6136311 – fax +39 045 7614663 – sales@pedrollo.com – www.pedrollo.com