



### PERFORMANCE RANGE

- Flow rate up to **400 l/min** (24 m<sup>3</sup>/h)
- Head up to **14.5 m**

### APPLICATION LIMITS

- Immersion depth:
  - **3 m** for TOP 1-2-3
  - **5 m** for TOP 4-5
 (with a sufficiently long power cable)
- Maximum liquid temperature **+40 °C**  
(Maximum liquid temperature +90 °C for a maximum of 3 minutes intermittent service)
- Passage of suspended solids up to **Ø 10 mm**
- Suction level:
  - **14 mm** above ground level for TOP 1-2-3
  - **30 mm** above ground level for TOP 4-5
- Continuous service **S1**

### CONSTRUCTION AND SAFETY STANDARDS

Complete with:

- **5 m** long power cable for TOP 1-2-3
- **10 m** long power cable for TOP 4-5
- float switch

EN 60335-1  
IEC 60335-1  
CEI 61-150

EN 60034-1  
IEC 60034-1  
CEI 2-3



### CERTIFICATIONS

COMPANY WITH MANAGEMENT SYSTEM  
CERTIFIED BY DNV  
ISO 9001: QUALITY  
ISO 14001: ENVIRONMENT AND SAFETY



AM30



ПРОМТЕКТ-168

### INSTALLATION AND USE

The **TOP** series is suitable for use with **clear water** that does not contain abrasive particles.

As a result of the design solutions that have been adopted, such as the complete cooling of the motor and the shaft with double seal, these pumps are easy to use and reliable.

They are suitable for use in applications such as draining small flooded areas (rooms, cellars, garages) in the event of an emergency, for the disposal of waste water in the home (from dishwashers, washing machines) and for emptying drainage traps.

### PATENTS - TRADE MARKS - MODELS

- Registered Community Design n° 342159-0011

### OPTIONALS AVAILABLE ON REQUEST

- “**TOP 2-3 LA**” pumps intended for use with aggressive liquids
- Special mechanical seal
- TOP 1-2-3 pumps with **10 m** long power cable
  - ➔ N.B. Standard EN 60335-2-41 states that the power cable must be 10 m long for outdoor applications
- Pumps without float switch
- Other voltages or 60 Hz frequency

### GUARANTEE

2 years subject to terms and conditions

**CHARACTERISTIC CURVES AND PERFORMANCE DATA**

**50 Hz n= 2900 1/min**

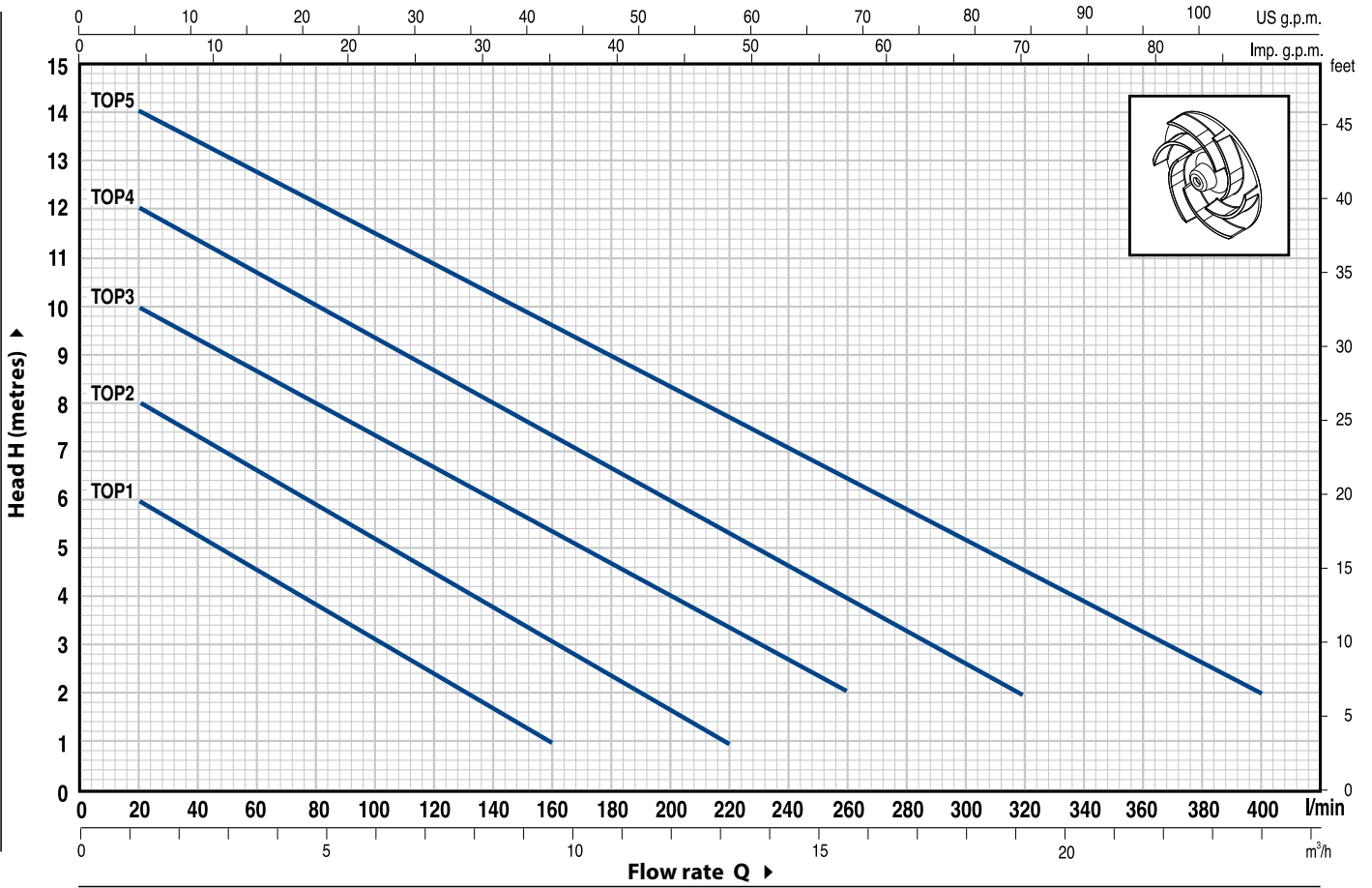

MODEL	POWER		Q	Flow rate																							
	kW	HP		0	1.2	2.4	3.6	4.8	6.0	7.2	8.4	9.6	10.8	12	13.2	14.4	15.6	16.8	18.0	19.2	20.4	21.6	22.8	24			
Single-phase			l/min	0	20	40	60	80	100	120	140	160	180	200	220	240	260	280	300	320	340	360	380	400			
<b>TOP 1</b>	0.25	0.33	H metres	7	6	5.5	4.5	4	3	2.5	1.5	1															
<b>TOP 2</b>	0.37	0.50		9	8	7.5	6.5	6	5.5	4.5	4	3	2.5	1.8	1												
<b>TOP 3</b>	0.55	0.75		10.5	10	9	8.8	8	7.5	6.5	6	5.5	4.8	4	3.5	2.5	2										
<b>TOP 4</b>	0.75	1		12.6	12	11.5	10.7	10	9.3	8.7	8	7.3	6.7	6	5.3	4.7	4	3.3	2.7	2							
<b>TOP 5</b>	0.92	1.25		14.5	14	13.5	12.7	12.1	11.5	10.8	10.2	9.6	8.9	8.3	7.7	7.1	6.4	5.8	5.2	4.5	3.9	3.3	2.6	2			

Q = Flow rate H = Total manometric head

Tolerance of characteristic curves in compliance with EN ISO 9906 Grade 3.

# TOP 1-2-3

POS.	COMPONENT	CONSTRUCTION CHARACTERISTICS				
1	PUMP BODY	Technopolymer				
2	SUCTION FILTER	Technopolymer				
3	SUCTION PLATE	Stainless steel AISI 304				
4	DIFFUSER	Technopolymer				
5	IMPELLER	Noryl GFN2V				
6	MOTOR CASING	Stainless steel AISI 304				
7	MOTOR CASING PLATE	Stainless steel AISI 304				
8	MOTOR SHAFT	Stainless steel EN 10088-3 - 1.4104				
9	<b>SHAFT WITH DOUBLE SEAL AND OIL CHAMBER</b>					
	<i>Pump</i>	<i>Seal</i>	<i>Shaft</i>	<i>Materials</i>		
	<i>Model</i>	<i>Model</i>	<i>Diameter</i>	<i>Stationary ring</i>	<i>Rotational ring</i>	<i>Elastomer</i>
	TOP 1-2-3	AR-12R	Ø 12 mm	Ceramic	Graphite	NBR
	TOP 2-3 LA	AR-12R LA	Ø 12 mm	Ceramic	Graphite	NBR
10	LIP SEAL	Ø 12 x Ø 19 x H 5 mm				
11	BEARINGS	6201 ZZ / 6201 ZZ				
12	<b>CAPACITOR</b>					
	<i>Pump</i>	<i>Capacitance</i>				
	<i>Single-phase</i>	<i>(230 V or 240 V)</i>		<i>(110 V)</i>		
	TOP 1	10 µF 450 VL	16 µF 250 VL			
	TOP 2	10 µF 450 VL	16 µF 250 VL			
	TOP 3	14 µF 450 VL	16 µF 250 VL			
13	<b>ELECTRIC MOTOR</b>					
	<ul style="list-style-type: none"> <li>- Single-phase 230 V - 50 Hz</li> <li>with thermal overload protector built-in to the winding</li> <li>- Insulation: F class</li> <li>- Protection: IP X8</li> </ul>					
14	<b>HANDLE ASSEMBLY</b> (resin sealed)					
	Complete with:					
	- 5 metre long "H07 RN-F" power cable with Schuko plug					
	- Float switch.					
15	<b>HOSE CONNECTOR WITH UNION</b>					
	Ø 25 mm hose connection for TOP 1					
	Ø 35 mm for TOP 2-3					

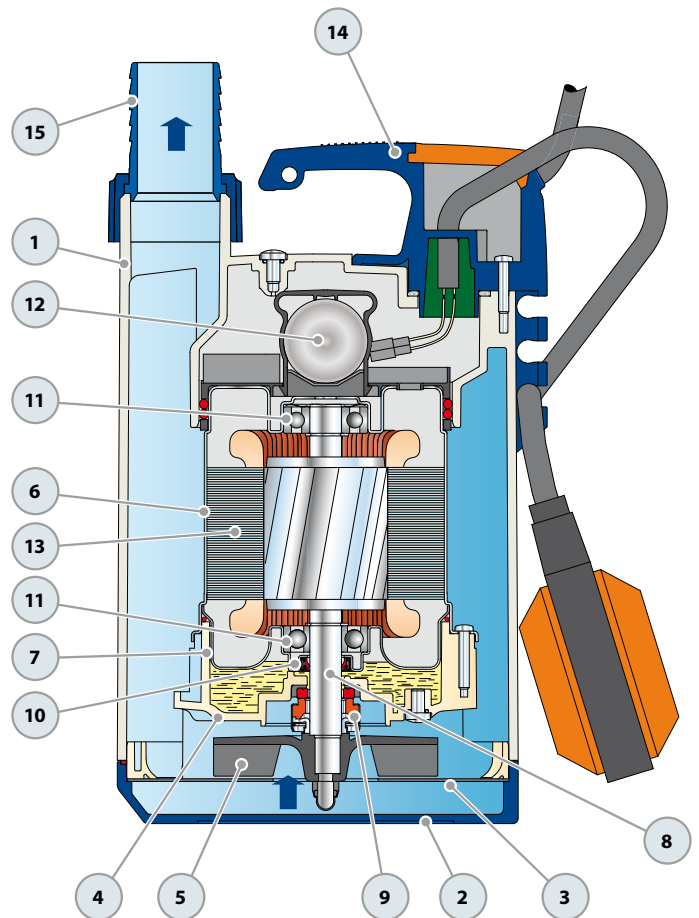

## DIMENSIONS AND WEIGHT

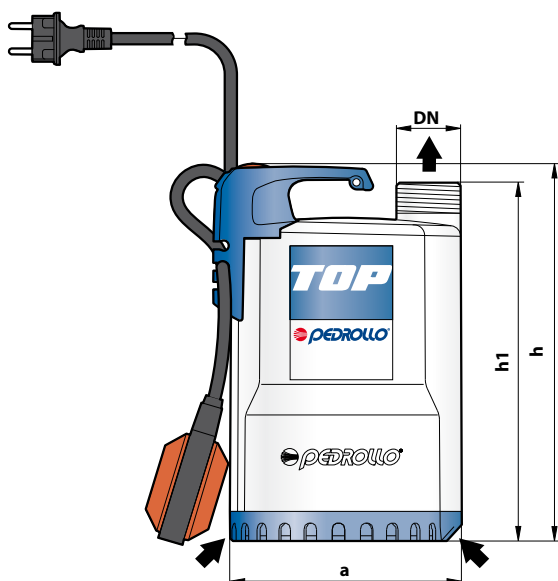

### Typical installation

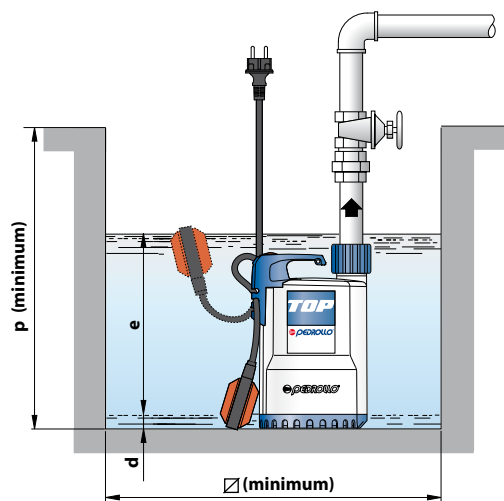

MODEL	PORT	DIMENSIONS mm							kg
		a	h	h1	d	e	p	Ø	
Single-phase	DN								
TOP 1	1 1/4"	152	257	237	14	variable	350	350	4.5
TOP 2				5.2					
TOP 3			287	267					6.6

## ABSORPTION

MODEL	VOLTAGE (single-phase)		
	230 V	240 V	110 V
Single-phase			
TOP 1	1.4 A	1.3 A	3.0 A
TOP 2	2.0 A	2.0 A	5.3 A
TOP 3	3.2 A	3.2 A	7.9 A

## PALLETIZATION

MODEL	GROUPAGE			CONTAINER		
	n° pumps	H (mm)	kg	n° pumps	H (mm)	kg
Single-phase						
TOP 1	96	1260	444	168	2100	765
TOP 2	96	1260	515	168	2100	888
TOP 3	96	1360	653	144	1970	971

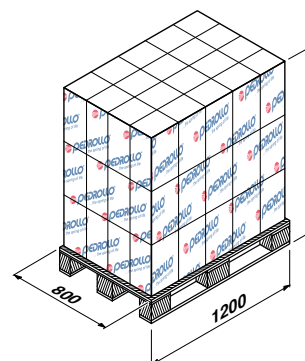

# TOP 4-5

POS.	COMPONENT	CONSTRUCTION CHARACTERISTICS	
1	PUMP BODY	Technopolymer	
2	SUCTION FILTER	Technopolymer	
3	SUCTION PLATE	Stainless steel AISI 304	
4	DIFFUSER	Technopolymer	
5	IMPELLER	Ryton	
6	MOTOR CASING	Stainless steel AISI 304	
7	MOTOR CASING PLATE	Stainless steel AISI 304	
8	MOTOR SHAFT	Stainless steel EN 10088-3 - 1.4104	
9	<b>SHAFT WITH DOUBLE SEAL AND OIL CHAMBER</b>		
	<i>Seal</i>	<i>Shaft</i>	<i>Materials</i>
	<i>Model</i>	<i>Diameter</i>	<i>Stationary ring</i> <i>Rotational ring</i> <i>Elastomer</i>
	MG1-14	Ø 14 mm	Ceramic   Graphite   NBR
10	LIP SEAL	Ø 16 x Ø 24 x H 5 mm	
11	BEARINGS	6203 ZZ / 6203 ZZ	
12	<b>CAPACITOR</b>		
	<i>Pump</i>	<i>Capacitance</i>	
	<i>Single-phase</i>	<i>(230 V or 240 V)</i>	<i>(110 V)</i>
	TOP 4	16 µF 450 VL	30 µF 250 VL
	TOP 5	20 µF 450 VL	30 µF 250 VL
13	<b>ELECTRIC MOTOR</b>		
	<ul style="list-style-type: none"> <li>– Single-phase 230 V - 50 Hz with thermal overload protector built-in to the winding</li> <li>– Insulation: F class</li> <li>– Protection: IP X8</li> </ul>		
14	<b>HANDLE ASSEMBLY</b> (resin sealed)		
	Complete with: <ul style="list-style-type: none"> <li>– 10 metre long "H07 RN-F" power cable with Schuko plug</li> <li>– Float switch.</li> </ul>		
15	<b>HOSE CONNECTOR WITH UNION</b>		
	Hose connection Ø 41 mm		
16	<b>PIPE COUPLING</b>		
	In technopolymer with 1½" thread and clapet valve		

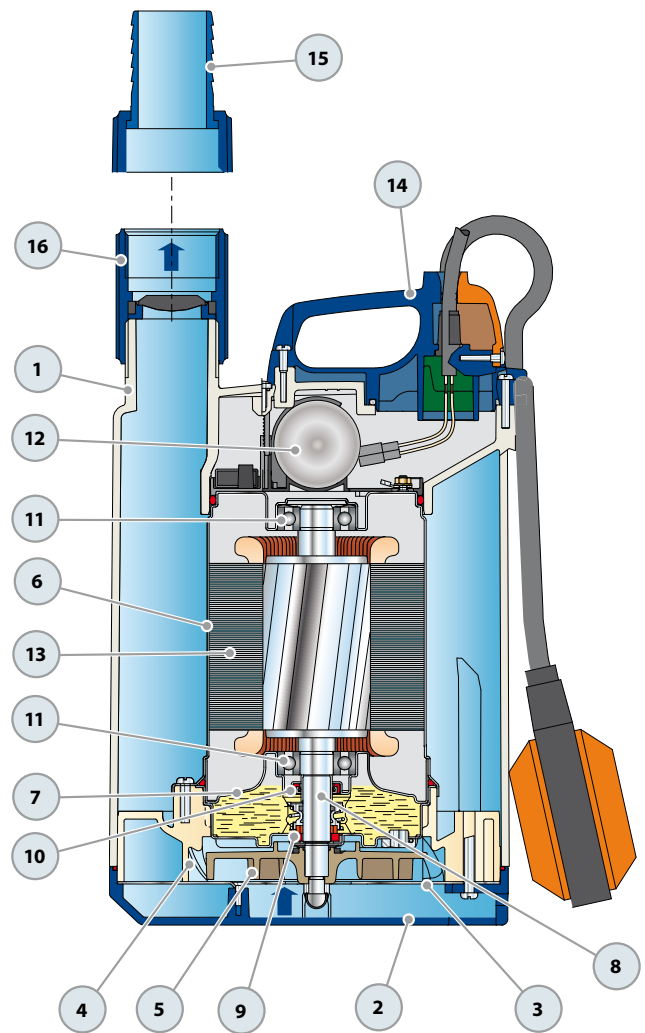

## DIMENSIONS AND WEIGHT

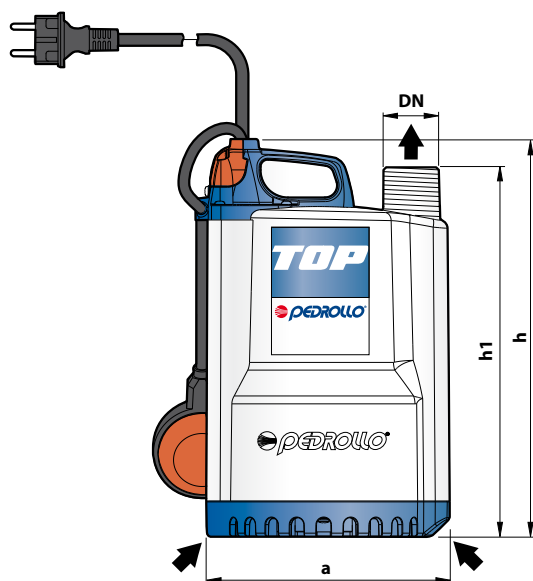

### Typical installation

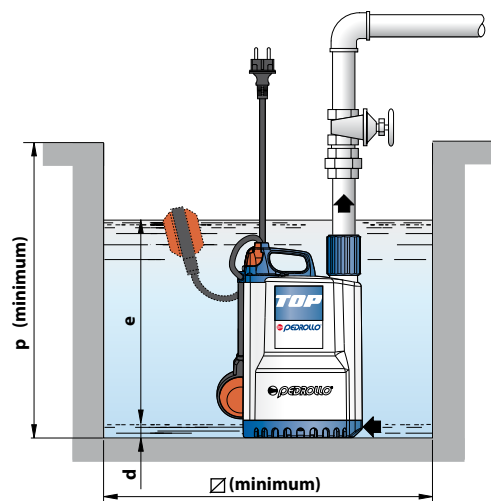

MODEL	PORT	DIMENSIONS mm							kg
		a	h	h1	d	e	p	Ø	
Single-phase	DN								
TOP 4	1½"	204	334	310	30	variable	450	450	10.1
TOP 5									11.1

## ABSORPTION

MODEL	VOLTAGE (single-phase)		
	230 V	240 V	110 V
Single-phase			
TOP 4	4.8 A	4.8 A	9.6 A
TOP 5	6.5 A	6.5 A	13.0 A

## PALLETIZATION

MODEL	GROUPAGE			CONTAINER		
	n° pumps	H (mm)	kg	n° pumps	H (mm)	kg
Single-phase						
TOP 4	54	1295	563	90	2065	928
TOP 5	54	1295	617	90	2065	1016

