

High crowned dolly
Tas americano
 Encontrador curvo

Art.	L mm	g
30823	85	1000



Wedge dolly
Tas de cuña
 Encontrador tipo cunha

Art.	L mm	g
30824	110	800



Curved dolly
Tas de coma
 Encontrador tipo vírgula

Art.	L mm	g
30825	135	1625



Car body spoon
Cuchara carrocerero
 Colher côncava

Art.	L mm	g
30826	390	1242



Chisel with straight cutter and hand guard,
 extra flat
Burril carrocerero con protección, extraplano
 Cinzel com cortante direito com punho de
 protecção, extra plano

Art.	L mm	g
30827	240	283



Double plunger elevator

- flexible suction cups and quick-release lever
- ideal for curved windscreens
- for lifting, carrying and holding
- for flat and non-porous surfaces
- special plastic

Ventosa para lunas

- flexible, de fácil liberación
- ideal para parabrisas curvos
- para levantar, transportar y sujetar
- para superficies planas y no porosas
- plástico especial

Ventosa dupla de sucção

- ventosas flexíveis com alavanca de libertação rápida
- ideal para os para-brisas curvos
- para elevar, transportar e segurar
- para superfícies planas e não porosas
- plástico especial

Art.	kg	Ø mm	L mm
30802	max. 40	117	327

ABS

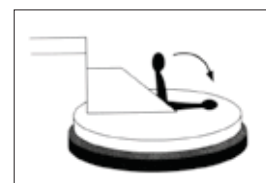

Double plunger elevator, aluminium

- flexible suction cups and quick-release lever
- ideal for curved windscreens
- for lifting, carrying and holding
- for flat and non-porous surfaces

Ventosa aluminio para lunas

- flexible, de fácil liberación
- ideal para parabrisas curvos
- para levantar, transportar y sujetar
- para superficies planas y no porosas

Ventosa dupla de sucção em alumínio

- ventosas flexíveis com alavanca de libertação rápida
- Ideal para os para-brisas curvos
- para elevar, transportar e segurar
- para superfícies planas e não porosas

Art.	kg	Ø mm	L mm
30803	max. 50	117	327

Alu

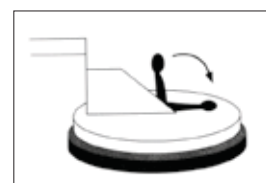

Windscreen wiper arm puller Extractor de brazos de limpiaparabrisas Saca limpa pára-brisas



Art.	L mm
30806	65

Wiper arm puller set

- allows trouble free disassembly of all current wiper arms
- perfect on rusty and stuck wiper arms
- helps protect nozzles inside the wiper arm by using the sliding hammer
- contains 1 sliding hammer, 1 pressure spindle, 6 sockets

Juego de extracción de brazos de limpiaparabrisas

- permite el desmontaje sin problemas de todos los brazos de limpiaparabrisas actuales
- perfecto para brazos oxidados y atascados
- ayuda a no dañar el brazo al extraerlo con barra deslizante
- incluye 1 barra deslizante, 1 husillo adaptador y 6 vasos

Jogo de sacas limpa pára-brisas

- permite a desmontagem sem problemas de todos os braços dos limpa pára-brisas
- perfeito para os braços oxidados e presos
- ajuda a proteger os injectores do interior dos braços utilizando o martelo deslizante
- contém 1 martelo deslizante, 1 eixo de pressão e 6 chaves

8
PCS



Art.	Pos.	
30807	1	Alfa-Romeo, Audi, BMW, Citroën, Fiat, Ford, Honda, Jaguar, Mazda, MB, Mercedes, MG-Rover, Mitsubishi, Opel, Peugeot, Renault, Seat, Skoda, Volvo, VW
	2	Alfa-Romeo, Audi, BMW, Citroën, Fiat, Ford, Honda, Hyundai, Jaguar, Land Rover, MB, Mercedes, Opel, Peugeot, Renault, Saab, VW
	3	Alfa-Romeo, Audi, BMW, Citroën, Fiat, Ford, Mazda, MB, Mitsubishi, Opel, Peugeot, Smart, Volvo, VW
	4	Citroën, Hyundai, MB, Mercedes, Opel
	5	Alfa-Romeo, Audi, BMW, Ford, Jaguar, Land Rover, Mazda, MB, Volvo, VW
	6	Citroën, Ford, Peugeot

✚ 325 x 250 x 80 mm

Hand riveter

Remachadora manual

Alicate de rebitar manual

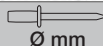
Art.	 Ø mm	L mm
2223	2.4-3.2-4.0-4.8	250



Nozzle for hand riveter

Boquilla para remachadora manual

Bico para alicate de rebitar manual

Art.	Ø mm
2223-2.4	2.4
2223-3.2	3.2
2223-4.0	4.0
2223-4.8	4.8



Pair of jaws for hand riveter

Par de bocas para remachadora manual

Mordentes para alicate de rebitar manual

Art.
2223-01





Hand riveter set

Kit remachadora manual

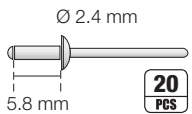
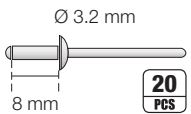
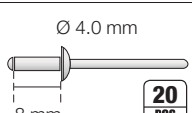
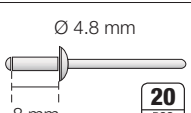
Conjunto de alicate de rebitar manual

 <p>Ø 2.4 mm 5.8 mm 20 PCS</p>	 <p>Ø 3.2 mm 8 mm 20 PCS</p>
 <p>Ø 4.0 mm 8 mm 20 PCS</p>	 <p>Ø 4.8 mm 8 mm 20 PCS</p>

Art.	 Ø mm	 pcs.
2224	2.4-3.2-4.0-4.8	20



Industrial lever type hand riveter tool case
Estuche remachadora manual con efecto de palanca
 Kit de alicate de rebitar de braços

Alu  inox

HIGHTECH

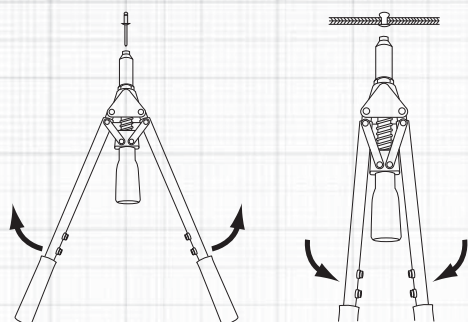

Art.	 mm
4262	3.2-4.0-4.8-6.0-6.4

 575 x 185 x 52 mm

Nozzle for hand riveter
Boquilla para remachadora manual
 Bico para alicate de rebitar manual

Art.	Ø mm
4262-1	3.2
4262-2	4.0
4262-3	4.8
4262-4	6.0
4262-5	6.4



Nozzle Monobolt for hand riveter
Boquilla Monobolt para remachadora manual
 Nariz Monobolt para alicate de rebitar manual

Art.	Ø mm
4262-8	4.8/5 / MB
4262-9	6.4 / MB



Pair of jaws for hand riveter
Par de bocas para remachadora manual
 Mordentes para alicate de rebitar manual

Art.
4262-7



Industrial lever hand rivet nut tool kit
Remachadora industrial para tuercas remachables
 Kit de alicate de rebitar de braços industrial

Alu  inox

HIGHTECH

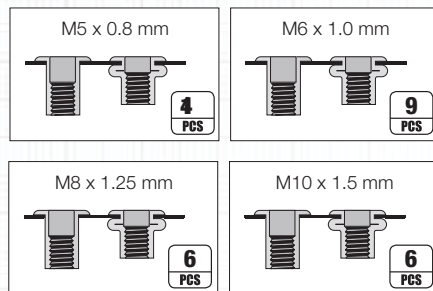

↕ 575 × 185 × 52 mm

Art.	
4264	M5-M6-M8-M10

Threaded mandrel and nose piece
Boquilla para remachadora de tuerca
 Mandril e bico para alicate de rebitar de braços industrial

Art.	
4264-1	M4
4264-2	M5
4264-3	M6
4264-4	M8
4264-5	M10



Long nose locking grip pliers
Tenaza grip de bocas largas
 Alicates de pressão bicos longos

Art.	L1 mm	L2 mm	L3 mm / inch
3292-150	50	45	max. 150 / 6

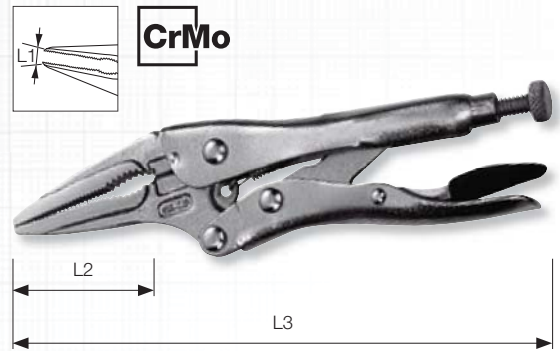

Sheet metal clamp
Tenaza grip para chapa
 Alicates de pressão para latoeiros

Art.	L1 mm	L2 mm	L3 mm / inch
2253-200	48	79	max. 200 / 8

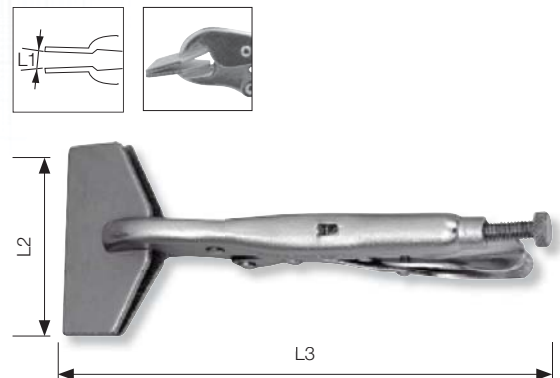

Locking welding clamp
Tenaza grip para soldador
 Alicates de pressão para soldadura

Art.	L1 mm	L2 mm / inch
2252-225	41	max. 225 / 9

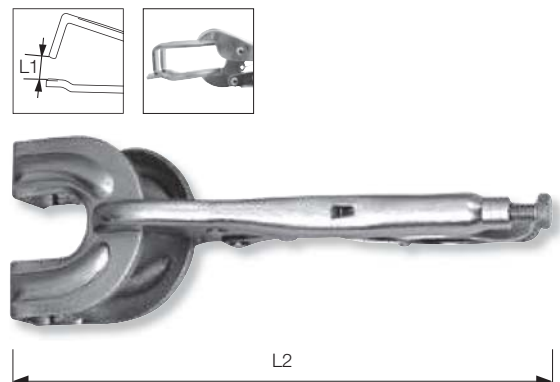

Locking „C”- clamp pliers
Mordaza grip de cuello de cisne
 Alicates de pressão pescoço de cisne

Art.	L1 mm	L2 mm	L3 mm / inch
2254-275	95	95	max. 275 / 11

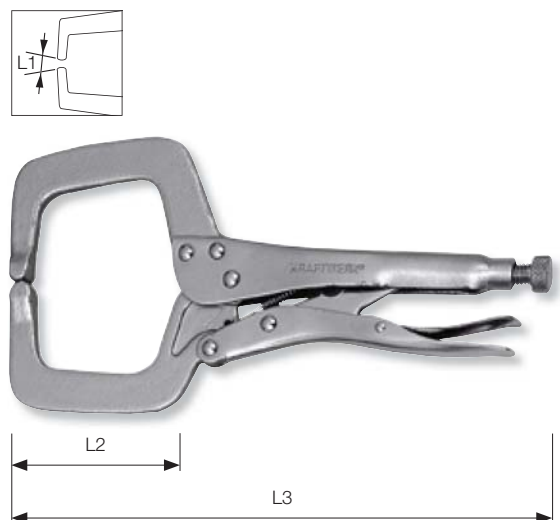

Plastic grip clamp set

Juego de pinzas de sujeción de plástico

Jogo de grampos multiuso plástico

Art.	L1 mm	L2 mm	L2 inch	PCS
2256	35	75	3	2
	40	100	4	2
	70	150	6	2
	85	225	9	2



Spatula, flexible

- flexible blade made of stainless steel, hardened and mirror polished
- bi-material soft grip handle with anti-slip grip

Espátulas, flexible

- lama flexível em aço inoxidável, reforçada e com acabamento pulido brilhante
- mango bimatéria antiderrapante

Espátulas, flexível

- lâmina flexível em inox, reforçada e polida
- cabo em bimatéria anti-derrapante

Art.	B mm	L1 mm	L2 mm
3331-032	32	105	240
3331-050	50	105	245
3331-063	63	105	245
3331-075	75	105	245
3331-100	100	105	245
3331-125	125	105	245



ergokraft



Universal spatula set

- flexible blades made of stainless steel, hardened and mirror polished
- bi-material soft grip handles with anti-slip grips

Juego de espátulas universales

- lamas flexíveis em aço inoxidável, reforçadas e com acabamento pulido brilhante
- mangos bimatéria antiderrapantes

Jogo de espátulas universais

- lâminas flexíveis em inox, reforçadas e polidas
- cabos em bimatéria anti-derrapante

Art.	B mm
3335	32 - 50 - 75



ergokraft



Foldable jack stands, pair
Pareja de caballetes plegables
Par de preguiças dobrável

Art.	Min. mm	Max. mm	kg
3972	276	363	3

2T



Jack stands, pair
Pareja de caballetes
Par de preguiças

Art.	Min. mm	Max. mm	kg
3979	280	420	7

3T



Jack stands, pair
Pareja de caballetes
Par de preguiças

Art.	Min. mm	Max. mm	kg
38106	382	600	14.2

6T



Knee- and seat pad

- made of high density, water resistant PE-foam, 3 layers
- millimeter and angle pitch line

Almohadilla

- 3 estratos de espuma de polietileno de alta densidad, resistente al agua
- regla impresa en mm y líneas de graduación de ángulo

Protector de joelhos e outros

- fabricado em espuma PE de grande densidade, resistente a água, 3 camadas
- impresso com escala e ângulos



470 × 200 × 30 mm

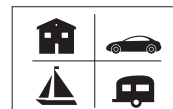

Art.

38001

ABS-plastic Workshop creeper

- solid and compact ABS-plastic design with transport handle
- extra deep and ergonomic shaped, adapted arm sections
- padded headrest
- tools and small parts compartment on both sides
- 6 easy turning rubber swivel rollers

Camilla de taller en ABS

- mono-bloc en ABS, sólida, compacta, resistente, con asa para transportar
- ergonomía máxima para el cuerpo y la colocación de los brazos
- reposacabezas acolchado
- compartimentos para útiles y pequeña herramienta en los dos lados
- 6 ruedas pivotantes en caucho

Estrado de mecânico

- sólido, compacto e indestrutível ABS plástico equipado com pega de transporte
- forma ergonómica especial para o corpo, secções ajustáveis para os braços
- encosto de cabeça almofadado
- compartimentos para ferramentas e peças pequenas em ambos os lados
- 6 rodízios giratórios em borracha.

max. 120 kg ABS



1010 × 480 × 115 mm

Art.

3991

De Luxe creeper

with 6 swivel wheels. Thick and comfortable foam rubber cushion.

Camilla de Luxe

con 6 ruedas pivotantes. Fina, comfortable, acolchado con espuma gruesa.

Esteira deluxe

com 6 rodas giratórias. Acolchoamento espesso e confortável de espuma emborrachada.

max. 180 kg



1135 × 510 × 185 mm

Art.

3988

Cross rim wrench
Llave ruedas cruz
Chave de rodas em cruz

CrV

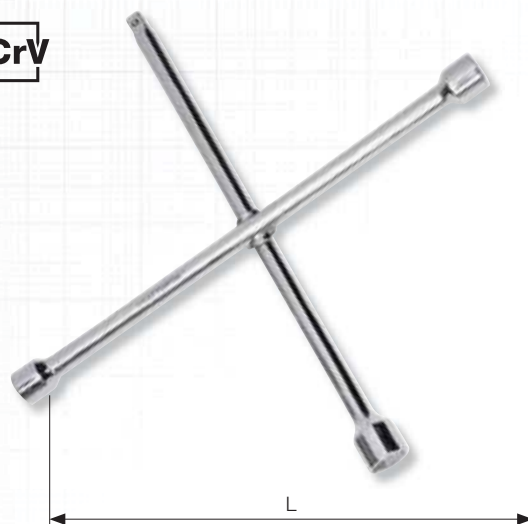

Art.	mm	mm	L mm
2585-12	17-19-22	1/2"	375
2585-34	24-27-32	3/4"	625

L type wheel wrench with double socket
extensible

Llave ruedas en L con llave de vaso doble
extensible

Chave de rodas tipo L com chave dupla
extensível

Art.	mm	L1 mm	L2 mm
2585-1719	17 x 19	365	525
2585-1721	17 x 19 21 x 22	365	525

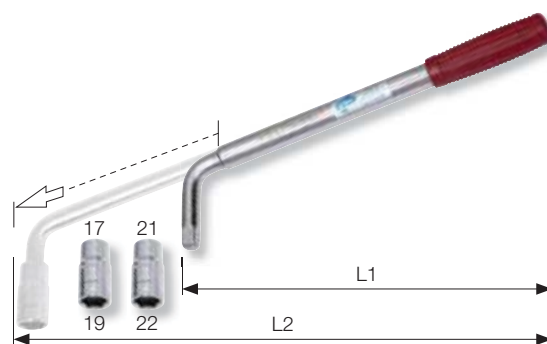

Torque multiplier set

with 7 chrome-molybdene impact sockets

Juego de multiplicador de par
con 7 vasos de impacto en cromo-molibdeno

Jogo de multiplicador de torque
com 7 chaves de impacto em cromo-molibdênio



1"	7	24-27-30-32-33-36-38 mm	78 mm
3/4"	1	3/4"	75 mm

Art.	L mm
30213	270



405 x 310 x 95 mm

Torque wrenches refer to chapter 8
Llaves dinamométricas ver capítulo 8
Chaves dinamométricas ver capítulo 8



Pneumatic impact wrench

specially short and light weight design with aluminium housing, heavy duty twin hammer gear for strong max. torque of 744 Nm - 3 steps.

Pistola neumática de impacto

Modelo corto y ligero con carcasa de aluminio, martillos gemelos de gran capacidad, max. 744 Nm ajustable en 3 posiciones.

Chave de impacto pneumática

Curta, compacta e leve com corpo de alumínio. Sistema de martelo duplo para um torque máx. 744 Nm – 3 posições de ajuste.



Alu



1/2"	744	140-680	9000	1200	>3.6	90

1.6	125	1/4"	10	164	10	6.2-7

Art.
3834

Air tool case

with impact wrench 1/2" 3834 and ratchet wrench 1/2" with socket quick release function. Including the 5 most used sockets, extension bar and universal joint adapter.

Conjunto neumática

con pistola 1/2" 3834 y carraca 1/2" con extracción rápida. Incluye 5 vasos más utilizados, alargadera y adaptador universal.

Conjunto pneumático

de chave 1/2" 3834 e roquete de impacto 1/2" com função de ejeção rápida das chaves. Incluindo as 5 chaves de impacto mais usadas, extensão e cardan.

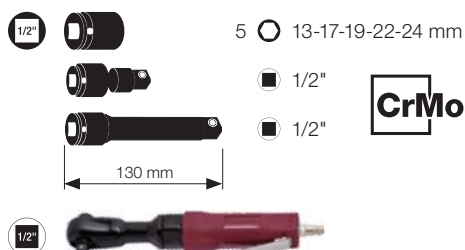

CrMo

1/2"	68	14-60	160	<4	90	260

1.22	1/4"	10	BSP	164	10	6.3

Art.
31015

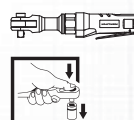

375 x 270 x 80 mm

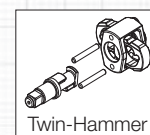

Industrial impact wrench

with impact proof composite housing. Super twin hammer gear with extreme torque 1486 Nm, 3 steps, one-handed operation for left- and right hander.

Pistola neumática industrial de impacto

estructura resistente a golpes, en composite. Martillos gemelos para máximo 1486 Nm, ajustable 3 grados, utilizable con una sola mano por diestro y zurdo.

Chave de impacto pneumática industrial

fabricada em compósito resistente ao choque engrenagem de martelo gêmeo e um torque extremo de 1486 Nm, ajustável em 3 estágios, para uso com uma mão direita e para canhotos.

1/2"	max.1486	68-810	8000	1250	>2.5	89
1.9	170	1/4"	10	142	10	6.2-7
Art.						
3837						



Universal impact wrench tool case

with industrial impact wrench 1/2" dr. 3837, 20 impact sockets in CrMo, 2 extension bars and socket-adaptor 3/4" dr. In plastic case fitting the HIGHTECH tool-cabinets.

Estuche universal de herramientas neumáticas de impacto

con pistola neumática industrial de impacto 1/2" 3837, 20 vasos de impacto en CrMo, 2 alargaderas y adaptador para vaso 3/4". En maleta plástica adecuada para los carros HIGHTECH.

Conjunto universal ferramentas pneumáticas impacto

com chave de impacto industrial de 1/2" 3837, 20 chaves caixa de impacto en CrMo, 2 extensões e adaptador para chaves caixa 3/4". Vem numa mala de plástico adequado para carros HIGHTECH.

		12	10-11-13-14-15-17-19 21-22-23-24-27 mm
		3	23-24-27 mm
		5	15-17-19-21-22 mm
			125 mm
			65 mm

Art.	
3837K	



410 x 270 x 90 mm

Impact socket wrench set
Juego de llaves de vaso impacto
Jogo de chaves impacto

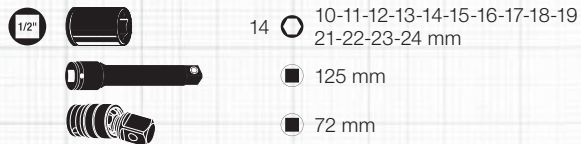

Art.
380005

Deep impact socket wrench set
Juego de llaves de vaso largas impacto
Jogo chaves de caixa longa impacto

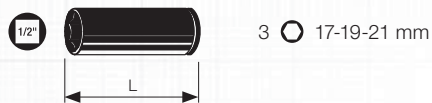

Art.	L mm
381099	85

Deep impact socket wrench set
with plastic insert to protect the wheel nuts and plastic sleeve for aluminium rims

Juego de llaves de vaso largas impacto con inserto plástico para proteger las tuercas de rueda y manga plástica para llantas en aluminio

Jogo de chaves impacto
com protecção plástica para proteger as porcas das rodas e manga plástica para as jantes de alumínio

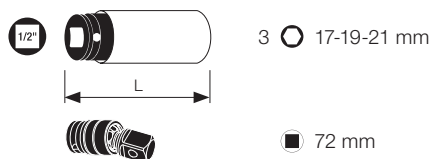

Art.	L mm
3083	85



270 × 185 × 58 mm

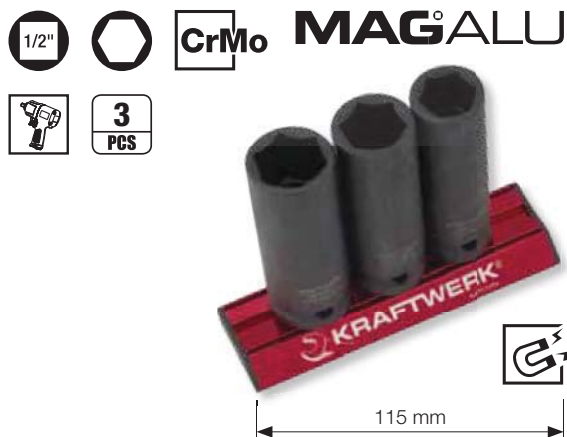

Deep impact socket wrench set

with plastic insert to protect the wheel nuts and plastic sleeve for aluminium rims

Juego de llaves de vaso largas impacto

con inserto plástico para proteger las tuercas de rueda y manga plástica para llantas en aluminio

Jogo de chaves impacto

com protecção plástica para proteger as porcas das rodas e manga plástica para as jantes de alumínio

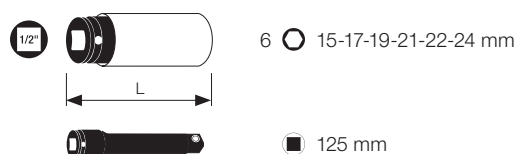

Art.	L mm
381005	85



± 212 × 151 × 48 mm

Universal impact socket set

in COMPLETO carrying case

Juego universal de llaves de vaso impacto

en estuche COMPLETO

Jogo universal de chaves impacto

em mala COMPLETO

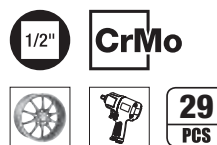

COMPLETO



Art.	
4900-70K	1/2"
4900-70B	without case / sin maletín / sem caixa



± 421 × 200 × 68 mm

Wobble impact adapter set

Juego de adaptadores/reductores articuladas de impacto

Jogo de adaptadores/redutores de impacto

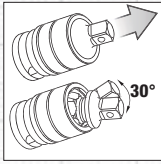

Art.	□	■	L mm
387999	1/4"	3/8"	36
	3/8"	1/4"	44
	3/8"	1/2"	48
	1/2"	3/8"	57
	1/2"	3/4"	70

Impact socket adapter set

with locking function

Juego adaptadores de impacto para vasos con bloqueo

con bloqueo

Jogo de adaptadores de impacto

com fecho automático

Art.	●	■	L mm
381014	1/4"	1/4"	75
381038	1/4"	3/8"	75
381012	1/4"	1/2"	75
381003	1/4"	Set / Juego / Jogo 1/4" + 3/8" + 1/2"	75

Impact socket adapter set

with locking function

Juego adaptadores de impacto para vasos con bloqueo

con bloqueo

Jogo de adaptadores de impacto

com fecho automático

Art.	●	■	L mm
381114	1/4"	1/4"	150
381138	1/4"	3/8"	150
381112	1/4"	1/2"	150
381103	1/4"	Set / Juego / Jogo 1/4" + 3/8" + 1/2"	150

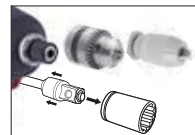
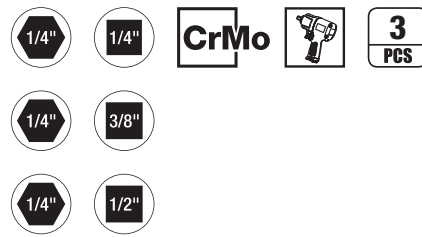
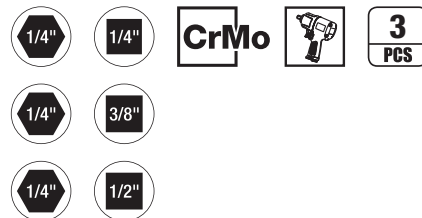
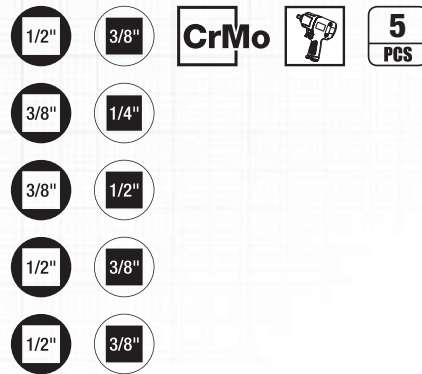

Car emergency tool and digital tyre gauge
*Herramienta de emergencia para coches
y medidor digital de presión para neumáticos*
Ferramenta de emergência para carros
e verificador digital de pressão de pneus



Art.

31008

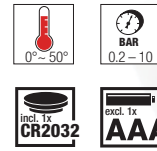

BLACKLINE

bar / psi / kpa



↕ 160 x 70 x 25 mm

Balancing wheel pliers
Alicate equilibrar ruedas
Alicate para pesos de rodas



HIGHTECH

Made in Germany



Art.



L
mm

4256-240

240

Mini combination crimping pliers
Mini alicata para engastar y pelacable
Mini alicata de cravar e descarnar



Art.		
3253	1.5-6 mm ²	1.5-6 mm ²



50C HRC 44-50

↕ L: 180 mm



Crimping pliers
Alicata para engastar terminales
Alicata de cravar terminais

Art.	 mm ²	 mm ²	L mm
2225	1.5 - 6	1.5 - 4.6	240



5-in-1 crimping and wire stripping pliers
GS-approved, hardened and with ground edges for professional and industrial use

Alicata para engastar con pelacables "5 en 1" aprobado GS, endurecido y con bordes redondeados para su uso profesional e industrial

Alicata 5-em-1 cravar e descarnar
aprovação GS, endurecido para uso profissional e industrial

Art.	 mm ²	 mm ²	L mm
3290-230	1.5 - 6	1.5 - 4.6	230

ergokraft



"K5" HRC 54



Bolt cutter
Para pernos
Corta parafusos



Crimping pliers for insulated terminals
Alicata para engastar terminales no aislados
Crava terminais isolados

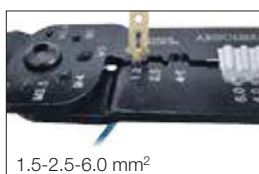

Crimping pliers for open barrel terminals
Engastar terminales abiertos
Crava terminais abertos



Wire cutter
Corta cable
Corta Fios

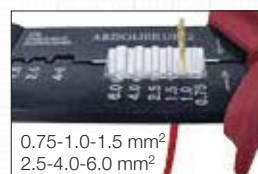

Wire Stripper for cables
Pelacable para
Descarnador de fios

Ratchet lever crimping pliers case

with interchangeable jaws including crimping jaws for insulated terminals and closed, non insulated terminals and non insulated ferrules. Empty compartments for supplementary jaws or to store terminals.

Estuche de alicates de carraca para engastar terminales

con cabezales intercambiables para terminales de cables aislados y terminales de cables sin aislar. Compartimentos vacíos para los cabezales suplementarios y depósito de terminales.

Alicate de roquete para cravar terminais em Estojo

com cabeças intermutáveis incluindo para terminais isolados e terminais não-isolados. Compartimentos vazios para cabeças suplementares.

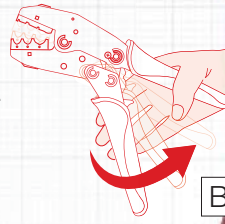

280 x 150 x 40 mm



DIN 0.5-1.0 / 1.5-2.5 / 4-6 mm²
AWG 20-18 / 16-14 / 12-10



DIN 1.5 / 2.5 / 6 / 10 mm²
AWG 20-18 / 16-14 / 12-10 / 8
JIS 1.25 / 2 / 5.5 / 8 mm²



Art.	incl.	L mm
3291	1x 3291-01 1x 3291-02	220

Optional crimp jaws

Bocas opcionales

Cabeças opcionais



Art. 3291-03
DIN 0.5-1.0 / 1.5-2.5 / 4-6 mm²
AWG 20-18 / 16-14 / 12-10



Art. 3291-04
DIN 0.5 / 0.75 / 1.0 / 1.5 / 2.5 / 4.0 mm²
AWG 22 / 20 / 18 / 16 / 14 / 12



Art. 3291-05
Coaxial RG 58.59.62.6.
6.48 / 5.41 / 2.5 / 1.72 / 8.23 mm²
0.255 / 0.213 / 0.1 / 0.68 / 0.324"



Art. 3291-06
DIN 6 / 10 / 16 mm²
AWG 10 / 8 / 6



Art. 3291-07
4P4C / RJ22



Art. 3291-08
6P2C / 6P4C / RJ11
6P6C / RJ12



Art. 3291-09
8P8C / RJ45



Art. 3291-10
DIN 2.5 / 0.5 / 8-10 mm²
AWG 14 / 22 / 8-6

Spark plug pullers

for damage free removal of ignition coils. Prevents damage and expensive replacement of the coil.

Juego de extractores de bobinas de encendido

para el montaje y desmontaje de bobinas de encendido.

Previene daños en la bobina.

Conjunto de extractores de bobinas de ignição

para a remoção segura de velas de ignição e bobinas de ignição.

Evita danos e substituição dispendiosa da bobina.

4
PCS



↕ 285 × 160 × 50 mm

Art.	
30642	VW

Spark plug socket remover

- especially for metal-coated spark plug sockets on VW engines
- prevents spark plug wires from damage during assembly

Removedor bujías

- especial para las bujías recubiertas de metal en los motores de VW
- evita daños en los cables de las bujías durante el montaje

Chave de velas encandescentes

- especialmente para velas revestidos de metal em motores VW
- evita danos à ignição durante a montagem.



← L →

Art.	L mm
30640	230

Universal joint spark plug wrench

Llave de bujía articulada

Chave de velas articulada

Art.	Ø mm	L mm
2591-16	16	240
2591-21	21	245

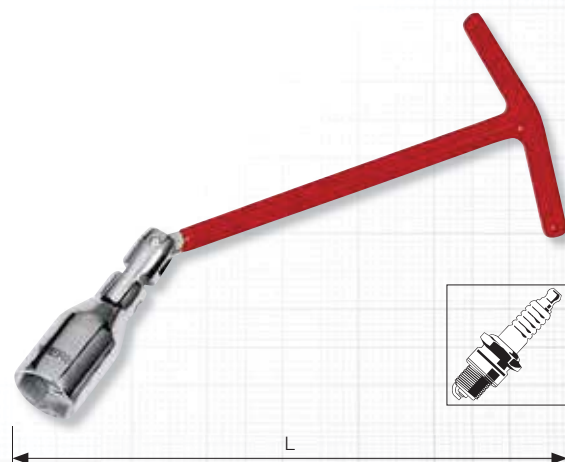

← L →

Spark plug pullers

for damage free removal of ignition coils. Prevents damage and expensive replacement of the coil.

Juego de extractores de bobinas de encendido

para el montaje y desmontaje de bobinas de encendido.

Previene daños en la bobina.

Conjunto de extractores de bobinas de ignição

para a remoção segura de velas de ignição e bobinas de ignição.

Evita danos e substituição dispendiosa da bobina.

4
PCS



↕ 285 × 160 × 50 mm

Art.	
30642	VW

Spark plug socket remover

- especially for metal-coated spark plug sockets on VW engines
- prevents spark plug wires from damage during assembly

Removedor bujías

- especial para las bujías recubiertas de metal en los motores de VW
- evita daños en los cables de las bujías durante el montaje

Chave de velas encandescentes

- especialmente para velas revestidos de metal em motores VW
- evita danos à ignição durante a montagem.



Art.	L mm
30640	230

Universal joint spark plug wrench

Llave de bujía articulada

Chave de velas articulada

Art.	Ø mm	L mm
2591-16	16	240
2591-21	21	245

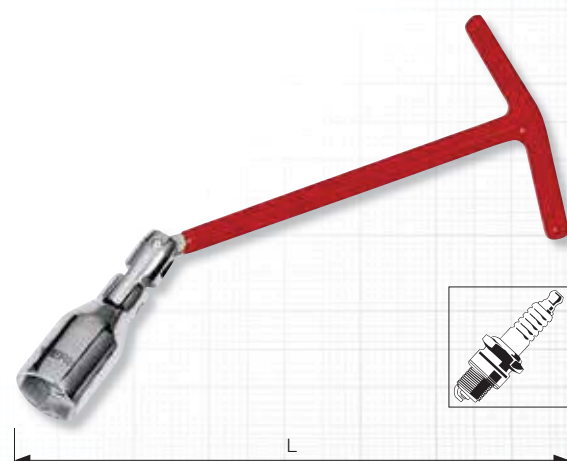

Heavy duty oil filter chain wrench

- heavy duty tool with duplex chain
- claw prevents slipping
- 180° swivel handle
- easy to use due to special chain-lock

Llave de filtro de cadena

- herramienta gran potencia de doble cadena
- garra para evitar el deslizamiento
- mango giratorio 180°
- fácil de usar debido al bloqueo especial de la cadena

Chave de filtros de corrente para trabalhos pesados

- ferramenta de serviço pesado com corrente dupla
- previne a garra de deslizar
- articulação giratória de 180°
- fácil de usar devido à corrente de bloqueio especial

Art.	Ø mm	L1 mm	L2 mm
30613	60-105	230	22



Self gripping oil filter spiral wrench

3-arms

Llave de filtro de aceite en espiral

3 patas

Chave de filtros de óleo espiral

3 garras



Art.	Ø mm
30652	45-75



Self gripping oil filter spiral wrench

3-arms

Llave de filtro de aceite en espiral

3 patas

Chave de filtros de óleo espiral

3 garras



Art.	Ø mm
30614	80-120



Pro swivel oil filter wrench
Llave de filtros articulada
Chave de filtros banda metálica

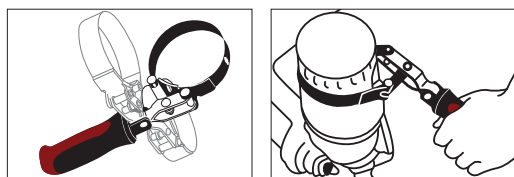

Art.	Ø mm
30616-076	60-76
30616-085	73-85
30616-099	85-99
30616-111	95-111



Pro swivel oil filter wrench
Llave de filtro articulada
Chave de filtros banda metálica

Art.	Ø mm
30617	65-110
30618	110-155



Swivel jaw filter wrench pliers

- can grip filters
- slipping around the filters is avoided by 6 heavy claws on each jaw

Alicate para filtros de aceite

- puede agarrar filtros
- evita el deslizamiento alrededor de los filtros 6 puntos de agarre fuertes en cada garra

Alicate de filtros ajustável

- os filtros podem apertar
- o deslizamento em torno dos filtros é evitado pelas seis garras pesadas em cada maxila

Art.	Ø mm	L1 mm
30615-120	57-120	325
30615-190	80-190	400



Drain plug key with metal bar

suitable for all cars

Llaves universales de tapón de carter

apto para todos los coches

Kit de chaves para bujões

apropriado para todos os carros



Art.	mm	mm
30623	14 + 17 10 + 12 9 + 5/16"	8 + 13 11 + 3/8"

Differential filter spanner

Llave de tuerca de filtro de aceite del embrague

Chave para filtros diferencial



Art.	mm	L mm	
30628	46	405	Škoda, VW

Oil drain plug socket set

on magnetic aluminum rail

Juego vasos para tapones de carter

sobre regleta magnética en aluminio

Jogo chaves parafusos drenagem

em suporte magnético de alumínio

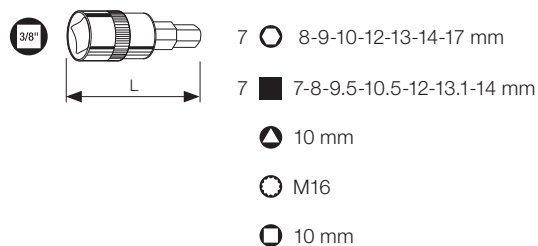

Art.	L mm
30010	35

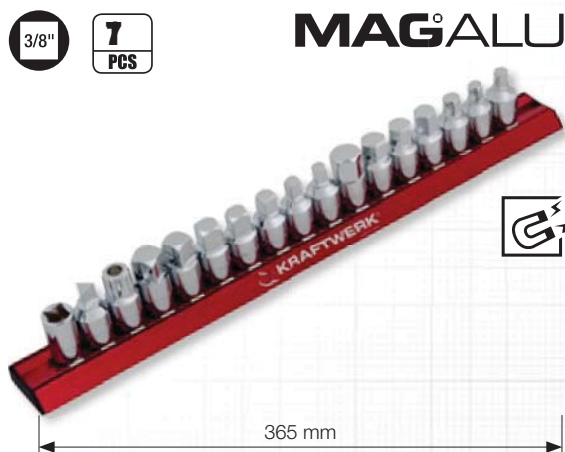

Info
KRAFTWERKtools.com/info/30010

Hydraulic spindle- and wheel hub

- universal use for nearly all cars with 4- and 5-hole hub due to different distances between the holes
- high power efficiency by hydraulic use
- Hydraulic capacity 12 tons

Extractor hidráulico de cubos de ruedas

- uso universal para la mayoría de 4 y 5 agujeros de fijación
- gran eficiencia por uso hidráulico
- capacidad hidráulica 12 toneladas

Extractor de cubos hidráulico

- universal para a maioria dos carros, de 4 e 5 furos
- grande poder de eficiência para uso hidráulico
- capacidade hidráulica 12 toneladas

Art.	
30214	Audi, Citroën, Fiat, Opel, Peugeot, Renault, Seat, Škoda, Volvo, VW, etc.

12T



Universal crank bearings puller tool set

for removing bearings, interior rings and other tightly fixed parts

Juego extractores de guillotina

para la extracción de los rodamientos, anillos internos y otras partes montadas de forma firme y ajustada

Conjunto sacas meia-lua

para remover rolamentos, interiores, e outras partes firmemente fixas e ajustadas



Art.	∅ mm
30401	30-50 50-70

↕ 275 × 205 × 55 mm

Universal puller set

2 and 3-arms, can be used as inner and outer puller.
 Exchangeable, hardened puller feet.

Juego universal de extractores

de 2 y 3 garras, permite operaciones de extracción internas y externas. Garras endurecidas e intercambiables.

Conjunto sacas universal

de 2 e 3 pernas, permite extrações internas e externas.
 Pernas do extractor endurecidas e intercambiáveis.

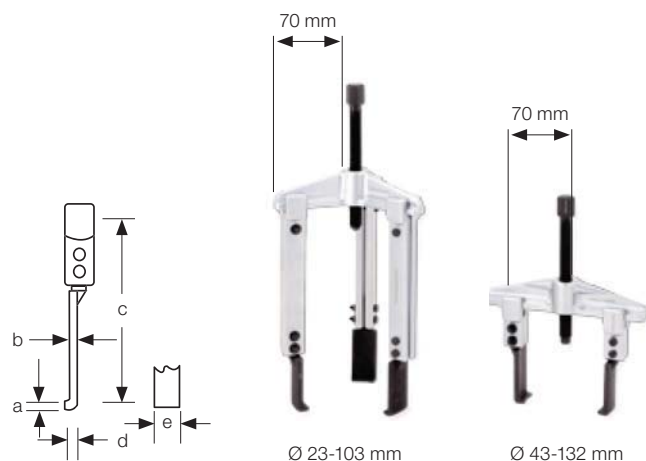

Art.	a	b	c	d	e
30402	3.6 mm	6 mm	100 mm	13 mm	27 mm
	3.6 mm	6 mm	200 mm	13 mm	27 mm
	3.6 mm	6 mm	250 mm	13 mm	27 mm

12
PCS



420 x 375 x 66 mm

Self adjusting clutch assemble tool

for proper removal and reinstallation as well as centering of self-adjusting 3-hole clutches

Autocentrador para embragues SAC

para desmontar y montar rápidamente embragues SAC con 3 agujeros

Conjunto aparelho de centrar embraiagem auto ajustável SAC

para remover e instalar as embraiagem auto ajustáveis com três pontos fixação



Art.



30403

Audi, BMW, Mercedes, Opel (Vauxhall), Renault

Ball joint puller

2-step adjustable, for pressing out the ball joints when removing ball joints from the stabiliser, steering knuckle, steering lever etc.

Extractor de rótulas

ajustable en 2 pasos, para extraer las articulaciones esféricas del estabilizador, rótula de dirección, palanca de dirección, etc

Extractor de rótulas

ajustável em 2 passos, para a extração das juntas esféricas do estabilizador, da rótula direção, braço de direção, etc.

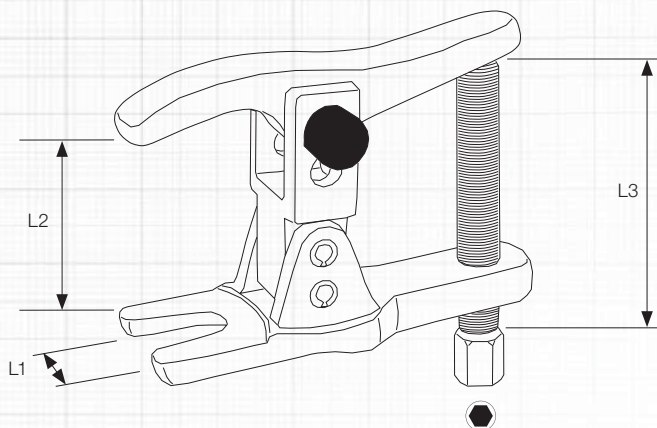

Art.	L1 mm	L2 mm	L3 mm	● mm
30404	22	40-110	130	17

CrMo



Universal ball joint puller

for pressing out the ball joints

Extractor universal de rótulas

para la extracción de las articulaciones esféricas en suspensiones

Extractor de rótulas universal

para a extração das rótulas esféricas

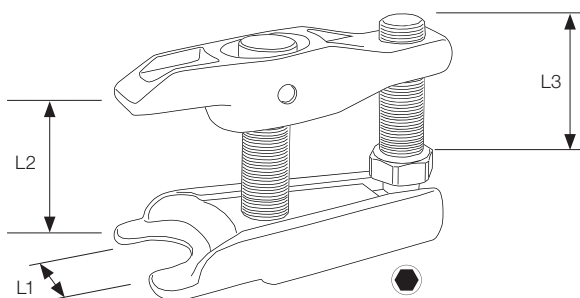

Art.	L1 mm	L2 mm	L3 mm	● mm
30405-20	20	50	54	19
30405-32	32	80	90	29

CrMo



Universal gear puller

- applicable for inside or outside pulling
- applicable with 2 or 3 arms

Extractor universal

- tomas interior y exterior
- extractor modulable por 2 ó 3 brazos

Extractor universal

- aplicável para interior ou exterior
- aplicável com 2 ou 3 braços

Art.	C min mm	C max mm	H mm	mm
4971-4	76	102	190	17
4971-7	76	178	270	19



4in1



Circlips pliers set

Juego de alicates para arandelas

Jogo de alicates de freios

4
PCS

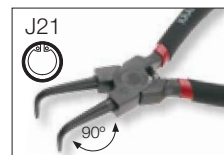

Art.	content / contiene / contém
2212	2212-A2, 2213-A21, 2214-J2, 2215-J21

Combined 4-in-1 circlips pliers

for external and internal circlips from 10 to 50 mm, with 4 tip-heads for 180°, 90°, 45° to be changed within seconds, for 6 different applications.

Alicate combinado 4-en-1 para arandelas

exteriores e interiores de 10 a 50 mm con 4 cabezas de puntas de 180°, 90°, 45°. Cambio de cabezas en segundos para 6 usos diferentes.

Alicate combinado 4-em-1 para freios

exteriores e interiores de 10 a 50 mm com 4 cabeças de ponta para 180°, 90°, 45°. Trocando cabeças em segundos para 6 aplicações diferentes.

4
PCS



Art.	Typ / mm	mm	L1 mm
2211	A1-A2, J1-J2 / 10-50 mm	1.35	155

Internal-external circlip pliers

Juego de alicates industriales para aros seger

Conjunto de alicates de freios para trabalhos pesados

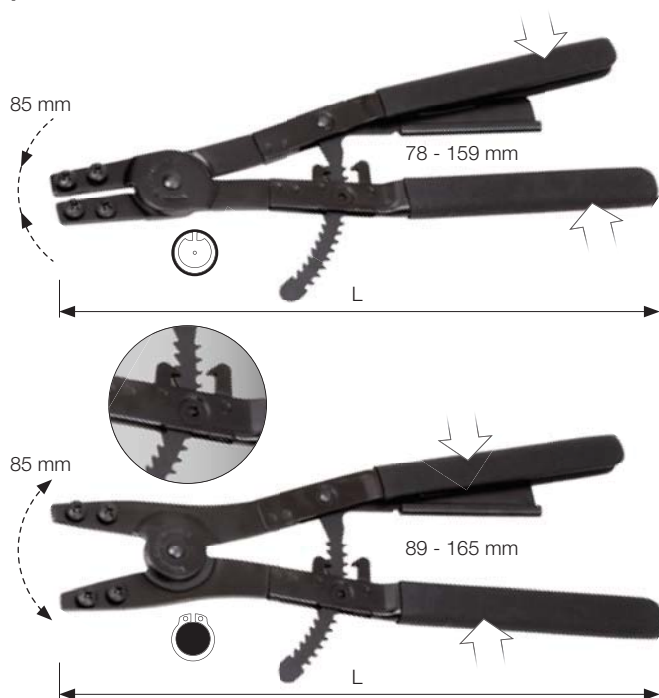

Art.	L mm
30015	400

CrMo **14**
PCS



438 x 334 x 66 mm



Special double X circlips pliers set

2 extra long circlips pliers for internal and external circlips, with 10 pairs of exchangeable tips. Double-X-system for an optimal power transmission.

Juego alicates especiales doble X para arandelas

2 alicates extra largos para arandelas interiores y exteriores, con 10 pares de puntas intercambiables. Sistema doble-X para una óptima transmisión de fuerza.

Conjunto alicates especiais Duplo X para anéis de fixação

2 alicates extra longos para freios interiores e exteriores, com 10 pares de pontas intercambiáveis. Sistema Duplo-X para uma excelente transmissão de força.

Art.	L mm
30006	340

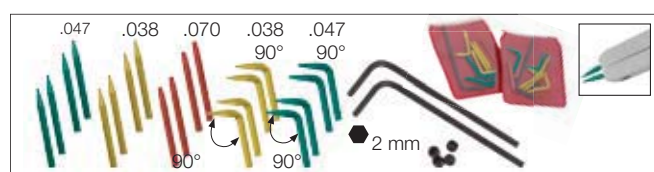

CrV **2**
PCS

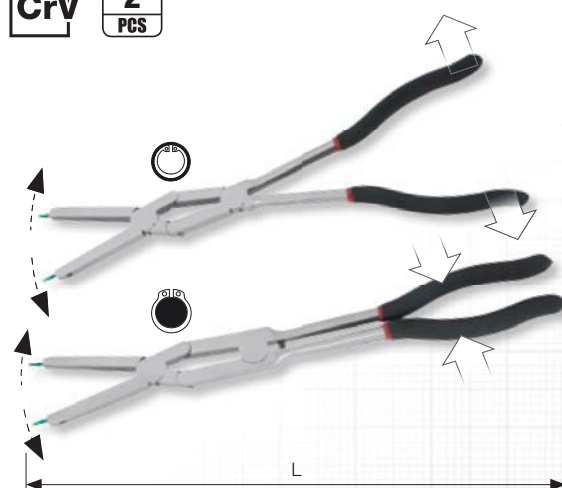

Bulb plier

Alicate para abrazaderas de manguitos

Alicate para lâmpadas

Art.	L1 mm	L2 mm
30013	160	0-34



Special double X pliers set

with 2 extra long nose pliers, straight and 45°.

Double-X-system for an optimal power transmission.

Juego alicates especiales doble X

con 2 alicates de manipulación extra largos, recto y 45°.

Sistema doble-X- para una óptima transmisión de fuerza.

Conjunto de alicates especiais duplo X

com 2 alicates de pontas extra longas, direitas e a 45°.

Sistema Duplo-X para uma excelente transmissão de força.

CrV **2 PCS**



Art.	L mm
30001	330

Nut splitter set

- for the mechanical splitting of faulty or overwound nuts without damaging the thread

- ideal for nuts up to strength category 6

Juego rompetuercas

- para extraer las tuercas sin dañar el espárrago

- ideal para tuercas con categoría de resistencia hasta 6

Conjunto de quebra porcas

- para a separação mecânica de porcas com defeito ou bloqueadas sem danificar o parafuso

- ideal para porcas até a categoria de força 6

Art.	Ø mm	L1 mm	L2 mm	L3 mm
30011	3-12	75	22	12
	12-17	101	31.5	14
	17-25	125	47.1	19
	25-32	148.6	57	21

4 PCS



± 215 × 165 × 51 mm

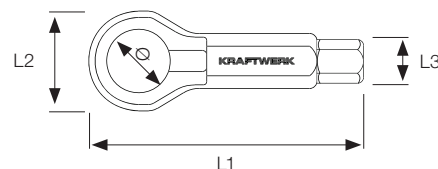

Torque wrench

with scale for values in Nm and Lb.ft. Instant reversible 45 teeth ratchet head. Hardened steel casing and ergonomic adjusting handle. Certified precision $\pm 4\%$.

Llave dinamométrica

con escala de valores en Nm y Lb.ft. Carraca reversible instantánea 45 dientes. Carcasa en acero reforzado y mango de ajuste ergonómico. Precisión certificada: $\pm 4\%$.

Chave dinamométrica

com escala para valores em Nm e Lb.ft. Reversível instantâneo com cabeça de 45 dentes em aço endurecido e punho ajustável ergonómico. Precisão certificada: $\pm 4\%$.

Art.	■	< ~ >	A Nm	L mm
2041	3/8"	5 - 25 Nm 4 - 19 Lb.ft	0.1	280
2041E	3/8"	Repair kit Kit de reparo Kit de reparação		
2040	1/2"	42 - 210 Nm 30 - 155 Lb.ft	1.0	470
2040E	1/2"	Repair kit Kit de reparo Kit de reparação		

3/8"

1/2"

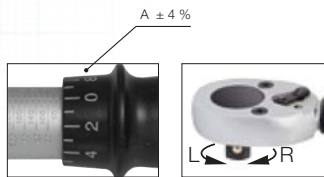

Art. 2040E / 2041E

Click torque wrench

with window scale for values in Nm and Lb.in. Instant reversible 45 teeth ratchet head. Hardened steel casing and ergonomic 2-component handle with locking adjusting knob. Certified precision: $\pm 4\%$.

Llave dinamométrica click

con ventana y valores en Nm y Lb.in. Carraca reversible instantánea 45 dientes. Carcasa en acero reforzado y mango ergonómico bimaterial con botón de ajuste. Precisión certificada: $\pm 4\%$.

Chave dinamométrica

com janela de escala para valores em Nm e Lb.in. Reversível instantâneo com cabeça de 45 dentes em aço endurecido e punho ergonómico de 2 componentes com bloqueio ajustável. Precisão certificada: $\pm 4\%$.

Art.	■	< ~ >	A Nm	L mm
3231	1/4"	2.5 - 12 Nm 20 - 105 Lb.in	0.05	285
3232	1/4"	4 - 20 Nm 30 - 180 Lb.in	0.05	285
3233	3/8"	10 - 60 Nm 9 - 45 Lb.ft	0.125	383
3234	3/8"	25 - 125 Nm 20 - 90 Lb.ft	0.25	438
3235	1/2"	40 - 200 Nm 30 - 150 Lb.ft	0.5	463
3236	1/2"	65 - 335 Nm 50 - 250 Lb.ft	0.5	523
3237	3/4"	160 - 800 Nm 120 - 600 Lb.ft	2.0	1040

1/4"

3/8"

1/2"

3/4"

ergokraft



DIN 3122 / ISO 3315

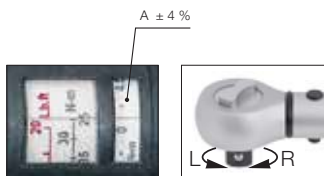

Digital torque / angle adapter

for tightening of screws at preset torque and/or angle values without changing tools. For clockwise and counter-clockwise tightening. Peak-/Track-mode. Read-out in lb.ft, lb.in or Nm. LED display and audible signal at achieved preset values. Presetting of 10 values, 50 memories. Including 2 AA-batteries and test certificate DIN EN ISO 6789.



Dispositivo dinamométrico digital / Adaptador angular

para apretar tornillos de forma controlada y definida incluso valores angulares sin cambiar de herramienta. Apriete en 2 sentidos, modo Peak-/Track. Lectura seleccionable en lb.ft, lb.in o Nm. Doble indicación: luminosa (LED) y acústica al llegar al valor seleccionado. Preselección 10 valores, 50 memorias. Incluye 2 baterías AA y certificado DIN EN ISO 6789.

Dispositivo dinamométrico digital / Adaptador angular

para apertar parafusos de forma controlada e definida incluindo valores angulares sem trocar de ferramenta. Aperto em 2 sentidos. Modo Peak-/Track. Indicação em lb.ft, lb.in ou Nm. Indicação dupla: luminosa (LED) e sonora ao atingir o valor seleccionado. Possibilidade de pré-seleccionar 10 valores, 50 memórias. Inclui 2 baterias AA e certificado DIN EN ISO 6789. 2 batterie tipo AA e certificato di collaudo DIN EN ISO 6789 inclusi.



Art.		
4082-12	40-200 Nm (±2%)	5°~ 360° (+/- 1%)

Magnetic holder

for sockets and pneumatic tools

Soporte magnético

para herramientas neumáticas

Suporte magnético

para ferramentas pneumáticas

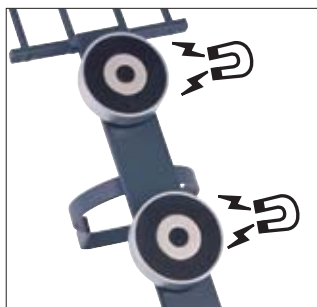

Art.	L mm
3929	400



Flexible telescope magnetic pick-up
Dedo magnético telescópico flexible
Pesca peças flexível magnético telescópico

Art.	Ø mm	L mm
3197	11	135 - 570



1500 g



4-in-1 Magnetic pick-up set
Juego dedos magnéticos 4 en 1
Kit 4-em-1 pesca peças magnético e espelho

Art.	L mm
3188	130 - 630



4
PCS

1500 g

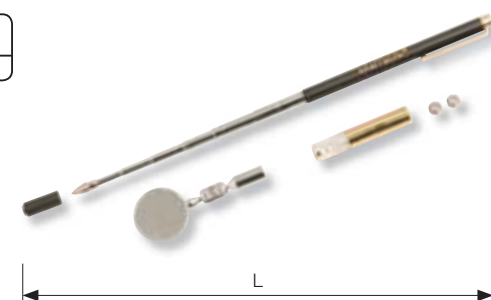

Telescope magnetic pick-up
Dedo magnético telescópico
Pesca peças telescópico magnético

Art.	Ø mm	L mm
3196	11	130 - 630



2000 g



Heavy duty flexible magnetic pick-up
Dedo magnético flexible
Pesca peças flexível magnético

Art.	Ø mm	L mm
3195	18	520



3500 g

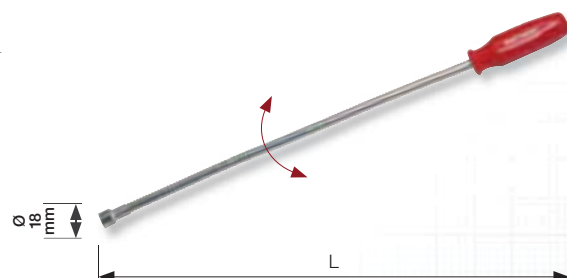

Flexible pick-up claw with magnet
Garra magnética flexible
Garra flexível com íman

Art.	L mm
3198	700



1000 g

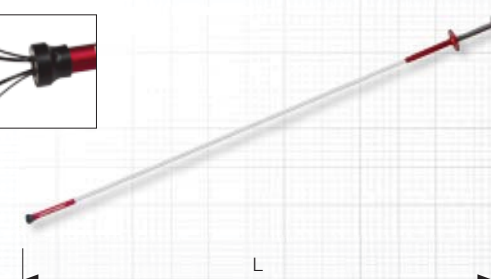

Magnetic pick-up, LED and mirror-set
Estuche dedos magnéticos/LED/set espejos
Kit pesca peças, espelho, LED

5
PCS

Art.	L mm
3190	176 - 660

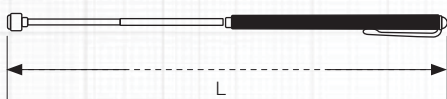

↕ 245 x 117 x 49 mm

Magnetic tray

stainless

Bandeja magnética

inox

Recipiente magnético

em aço inox

Art.
2950



1200 g



↕ Ø 150 x 40 mm

Magnetic tray

stainless

Bandeja magnética

inox

Recipiente magnético

em aço inox

Art.
2951















2x 1200 g















↕ 240 x 140 x 40 mm

Multi-function air-ratchet wrench
Carraca neumática multifunción
Roquete neumático

					
1/4"	40.7	6.7-40.7	850	>3	85
					
0.5	155	1/4"	10	113	6.2-7
Art.	L mm				
31011	156				



Air ratchet wrench, reversible
Carraca neumática
Roquete neumático

					
68	14-60	160	<4	90	260
					
1/4"	10	BSP	164	10	6.3
Art.		L mm	kg		
31012	3/8"	260	1.20		
31013	1/2"	260	1.22		



Blow-out gun for compressed air

- controlled air flow
- ergonomic handle

Sopladora de aire comprimido

- con flujo de aire controlado
- mango ergonómico

Pistola de soprar

- com ar comprimido controlado
- punho ergonómico

1/4"	132	1/4" BSP	14	<75

Art.	L1 mm	L2 mm	L3 mm
31030	240	100	80

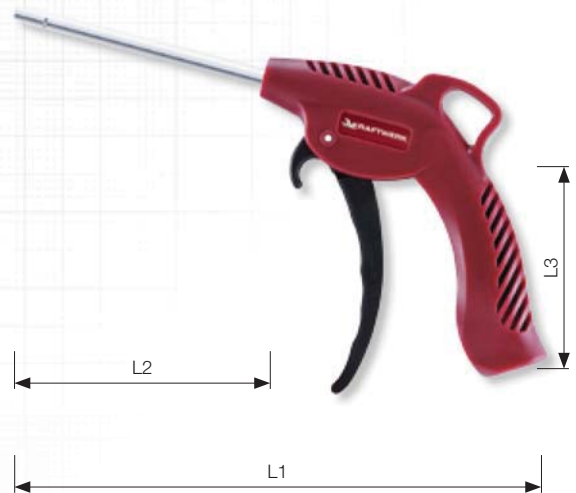

Telescopic blow-out gun for compressed air

- telescopic swivel nozzle
- ergonomic handle

Sopladora extensible de aire comprimido

- con ajuste del ángulo de la boquilla
- mango ergonómico

Pistola de soprar extensível

- com ponta giratória telescópica
- punho ergonómico

1/4"	144	1/4" BSP	14	<73

Art.	L1 mm	L2 mm	L3 mm
31031	300-435	165-300	80

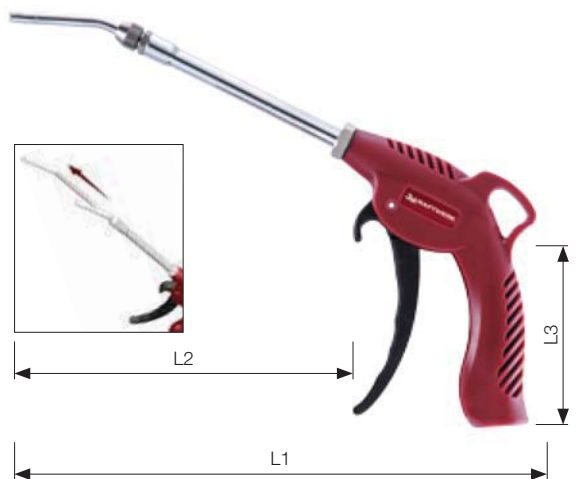

Blow-out gun for compressed air

with turbo nozzle and progressive airflow increment

Sopladora de aire comprimido

con boquilla efecto turbo y incremento progresivo del flujo de aire

Pistola de soprar

com ponta turbo e incremento progressivo do fluxo de ar

1/4"	467	1/4" BSP	14	<85

Art.	L1 mm	L2 mm	L3 mm
31032	180	40	80



Remover and pick set
Juego de ganzúas y picos
Conjunto de ganchos e furadores

7
PCS



Art.

4322

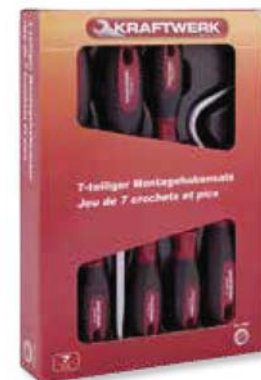

Telescopic ratchet pry bar

- ideal for use at difficult locations to reach
- adjustable head, lockable in 8 different positions
- ratchet mechanism during lifting
- high lever force
- 2 components ergonomic handle for best safety
- continuous variable telescopic bar, lockable

Palanca carraca articulada telescópica

- para uso en sitios de difícil acceso
- cabeza ajustable que se puede fijar en 8 ángulos diferentes
- mecanismo de carraca para apalancar
- efecto de palanca de gran elevación
- mango ergonómico bimatériau para mayor seguridad
- barra telescópica ajustable

Alavanca flexível efeito roquete

- para usar e chegar a sítios difíceis
- cabeça ajustável pode ser fixa em 8 posições diferentes
- mecanismo de roquete durante a elevação
- alta acção de alavanca
- cabo em bimatéria para uma melhor segurança
- barra telescópica ajustável



ergokraft

Art.

L ><
mm / inch

3337-18-30

450-750 / 18-30



Video

KRAFTWERKtools.com/video/3337

Aluminium working platform

Plataforma de trabajo en aluminio

Plataforma de trabalho em alumínio



Art.

L1
mm

L2
mm

L3
mm

kg

3985

965

480

300

8.2

max.
200
kg



15 W SMD LED 240 V work lamp

for motor, interior and under the car

- very bright 15 W SMD LED bulb
- electronic ballast for quicker start and longer life
- ratcheting hooks provide safe and firm attachment
- extensible and rotatable hooks from 113.8 to 190 cm
- for the utilization with most SUV and trucks
- soft coated padded hooks prevent scratching of the vehicles surface
- large hook design for the use as an interior and under car light
- 5 m cord H05WF 2 x 0.75mm²

Lámpara 15 W SMD LED de trabajo

240V para usar en el capó, debajo e interior de coche

- súper brillante, tubo SMD LED 15W
- casquillo electrónico para encendido rápido y de larga vida
- ganchos con trinquete para más seguridad y agarre firme
- ganchos telescópicos de entre 113.8-190 cm
- se engancha a la mayoría de los todo terreno y camiones
- recubrimiento blando de los ganchos previenen arañazos en la superficie de los vehículos
- gran forma del gancho permite que la lámpara sea utilizada también en el interior y debajo del coche
- cable: H05WF 2 x 0.75 mm²

Lâmpada de trabalho 15 W SMD LED

para capô, motor, interior e por baixo do carro, 240V

- LED brilhante 15 W SMD LED
- casquilho eletrônico para um início mais rápido e maior tempo de vida
- ganchos com roquete para uma fixação segura e firme
- ganchos telescópicos e rotativos de 113.8 a 190 cm
- para utilização em SUV e caminhão
- ganchos acolchoados e revestidos evitar arranhar a superfície dos veículos
- ganchos grandes para utilizar tanto no interior como no exterior do carro
- 5 m cabo, H05WF 2 x 0.75 mm²

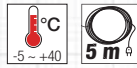

15W SMD-LED
150-400 LUX (1m)
400-1200 lm

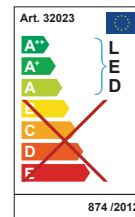
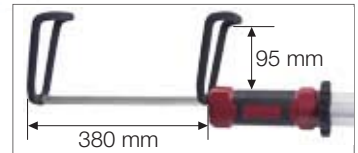

↕ 1138-1900 mm

Art.	
32023	15W SMD

Rechargeable 7 W SMD LED work light

for bonnet area, interior and under the car delivered with universal charger 100-240 V

Lámpara recargable de trabajo 7W SMD-LED

para usar en el capó, debajo e interior de coche suministrado con cargador universal 100-240 V

Lâmpada recarregável 7W SMD-LED

para capô, motor, interior e por baixo do carro entregue com carregador universal 100-240 V

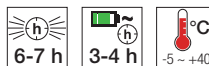

Li-Ion 7.4V (4000 mAh)

7W SMD-LED
150-200 LUX (1m)
450-550 lm

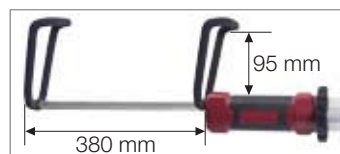

↕ 1200-1900 mm

Art.	
32024	7W SMD